

## Lecture 5: electricity

### Content:

- introduction
- electric charge, potential, field and current
- electric dipole
- resistance, conductance, Ohm's law
- resistivity, conductivity
- Kirchhoff's circuit laws
- dielectric materials, permittivity
- capacitor, capacitance
- alternating current
- skin effect, dispersion

# fundamentals of electric field

Electricity is the **set of physical phenomena** associated with the **presence and flow of electric charge**.

**Electric charge has a positive and negative sign.**

Electricity gives a wide variety of well-known effects, such as lightning, static electricity, electromagnetic induction and electric current (naturally originated).

In addition, electricity permits the creation and reception of electromagnetic radiation such as radio waves.

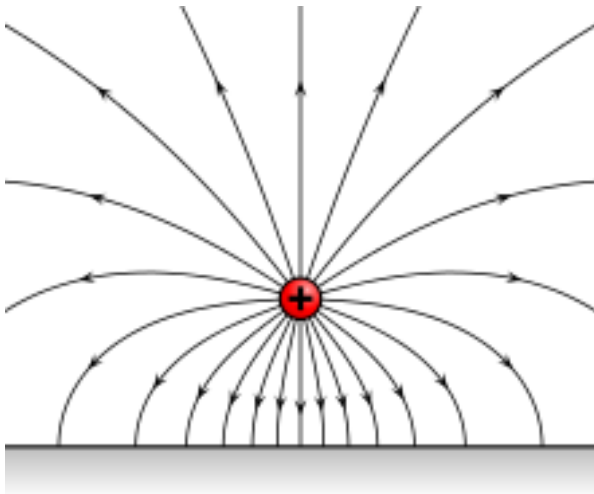

# fundamentals of electric field

## Charge carriers:

- in **metals**, the charge carriers are **electrons** (they are able to move about freely within the crystal structure of the metal). (a cloud of free electrons is called as a Fermi gas).
- in **electrolytes** (such as salt water) the charge carriers are **ions**, atoms or molecules that have gained or lost electrons so they are electrically charged (anions, cations). This is valid also in melted ionic solids.
- in a **plasma**, an **electrically charged gas** which is found in electric arcs through air, the electrons and cations of ionized gas act as charge carriers.
- in a **vacuum**, **free electrons** can act as charge carriers.
- in **semiconductors** (used in electronics), in addition to electrons, the travelling vacancies in the valence-band electron population (**called "holes"**), act as mobile positive charges and are treated as charge carriers.

interesting trials with plasma lamp:

<https://www.youtube.com/watch?v=2gttW4F86Sg>

# fundamentals of electric field

## Basic quantities:

- **electric charge**: a property of some subatomic particles, which determines their electromagnetic interactions. Electrically charged matter is influenced by, and produces, electromagnetic fields.
- **electric field** (electrostatic field): an especially simple type of electromagnetic field produced by an electric charge even when it is not moving (i.e., there is no electric current).  
the **electric field produces a force on other charges** in its vicinity.
- **electric potential**: the capacity of an electric field to do work on an electric charge, typically **measured in volts**.
- **electric current**: a movement or flow of electrically charged particles, typically **measured in amperes**.
- **electromagnets**: moving charges produce a magnetic field. Electric currents generate magnetic fields, and changing magnetic fields generate electric currents.

# electrical charge

Electric charge ( $Q$ ) is the physical property of matter that causes it **to experience a force** when placed in an electromagnetic field.

unit (SI system): coulomb  $[C] = [A \cdot s]$ ,

**1 coulomb is the charge transported by a constant current of one ampere in one second.**

Convention: direction of the charges movement (due to the potential difference) is taken in the way how the **positive charge** would move.

Twentieth-century experiments demonstrated that electric charge is quantized; that is, it comes in **integer multiples of individual small units called the elementary charge**,  $e$ , approximately equal to  $1.602 \cdot 10^{-19}$  coulombs (except for particles called quarks, which have charges that are integer multiples of  $e/3$ ).

The proton has a charge of  $+e$ , and the electron has a charge of  $-e$ .

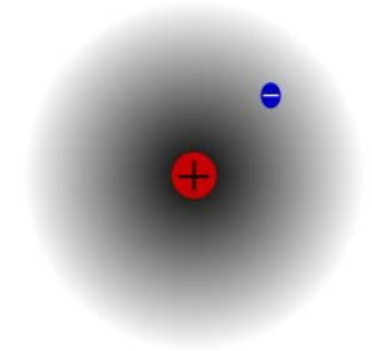
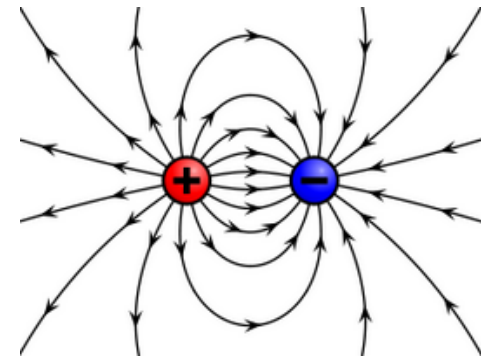

# electric charge – Coulomb's law

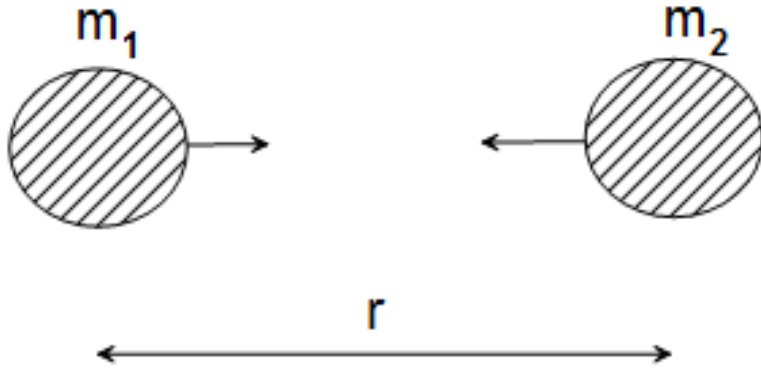

From the mechanics we know (Newton's gravity law) that two objects with masses are attracted by a force  $F_g$ , which is directly proportional to the product of their masses and inversely proportional to the square of the distance between them.

$$|\vec{F}_g| = F_g \approx \frac{m_1 m_2}{r^2}$$

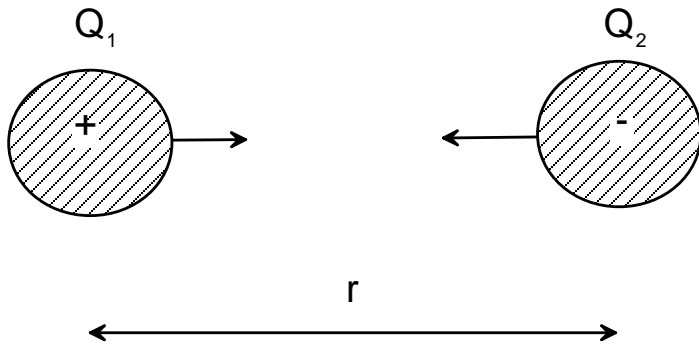

In the common influence of electric charges a similar law has been empirically recognized (by Charles Augustin de Coulomb) and called later on as Coulomb's law – also an inverse-square law for the electrical force  $F_e$ :



$$|\vec{F}_e| = F_e \approx \frac{Q_1 Q_2}{r^2}$$

# electric charge – Coulomb's law

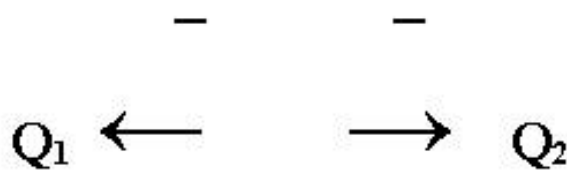
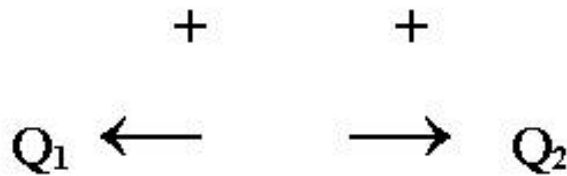
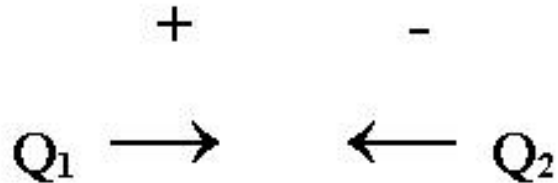

Charges with **opposite signs** are **attracted**, with **equal ones** they are **pushed away** from each other.

Full form of the Coulomb's law:

Size of the force between two point charges is directly proportional to the product of their masses and inversely proportional to the square of the distance between them.

$$|\vec{F}_e| = F_e \approx \frac{1}{4\pi\epsilon_0} \frac{Q_1 Q_2}{r^2}$$

where:

$Q_1, Q_2$  – electric point charges, unit [C]

$r$  – distance between point charges

$\epsilon_0$  – constant, so called

vacuum permittivity:

$8.854187 \cdot 10^{-12}$  [F·m<sup>-1</sup>] (farads per metre).

# electric charge – triboelectric effect

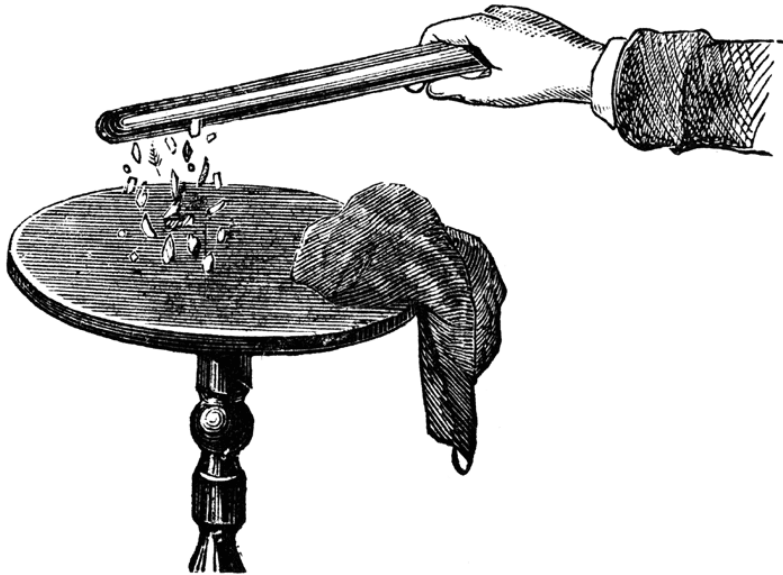

rubbing of different materials – static electricity:  
so called **triboelectric effect**





# electric charge – triboelectric effect

Dry Human Hands	More Positive
Rabbit Fur	
Glass	
Human Hair	
Fur	
Silk	
Paper ← Aluminium	
Wood	
Amber	
Polyester	
Styrofoam	
Plastic Wrap	
PVC	
Silicon	
Teflon	More Negative

During rubbing of a material, the surface electrons can move.

Material at the positive end has the tendency to loose electrons, so it **charges positively**.

Material at the negative end has the tendency to receive electrons, so it **charges negatively**.

# electric potential

Electric potential is a **scalar quantity** (denoted by  $V$ ,  $U$  or  $\phi$ ), equal to the electric potential energy of any charged particle at any location (measured in joules) divided by the charge of that particle (measured in coulombs).

unit: volt [V] = [J/C] = [kg·m<sup>2</sup>·s<sup>-2</sup>] / [A·s] = [kg·m<sup>2</sup>·s<sup>-3</sup>·A<sup>-1</sup>]

**1 volt is a potential difference between two points that will impart (transfer) 1 joule of energy per 1 coulomb of charge.**

Name Volt was selected after the Italian physicist (count) **Alessandro Volta**, the inventor of the electric battery (1800).

**Difference in electric potential between two points is known as voltage.**

# Inventor of a battery (a cell):

## Alessandro Volta (1800)

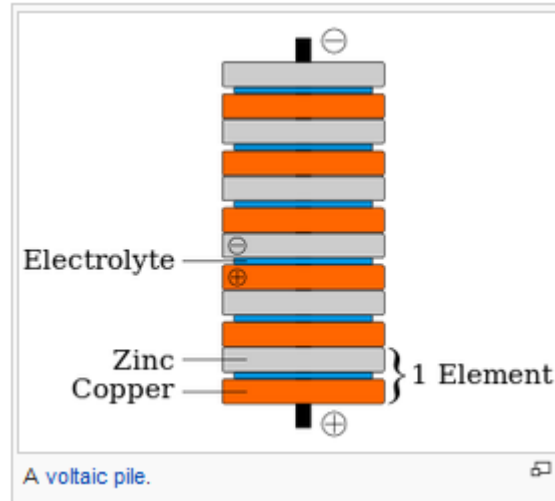
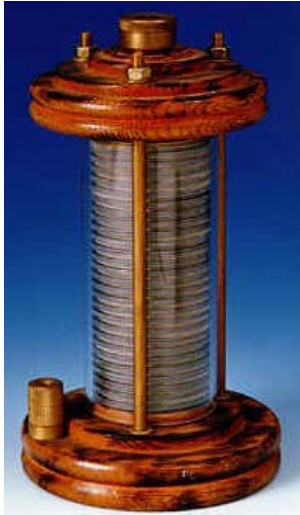

Two electrodes: one made of zinc, the other of copper. The electrolyte was sulfuric acid (consists of  $2\text{H}^+$  and  $\text{SO}_4^{2-}$ ). The zinc (higher in the electrochemical series than both copper and hydrogen) reacts with the negatively charged sulfate ( $\text{SO}_4^{2-}$ ). The positively charged hydrogen ions (protons) capture electrons from the copper, forming bubbles of hydrogen gas,  $\text{H}_2$ .

This makes finally the zinc rod the **negative electrode (anode)** and the copper rod the **positive electrode (cathode)**.

### Count Alessandro Volta



Alessandro Giuseppe Antonio Anastasio Volta

<b>Born</b>	18 February 1745 Como, Duchy of Milan
<b>Died</b>	5 March 1827 (aged 82) Como, Lombardy-Venetia
<b>Nationality</b>	Italian
<b>Fields</b>	Physics and chemistry
<b>Known for</b>	Invention of the electric cell Discovery of methane Volt Voltage Voltmeter
<b>Notable awards</b>	Copley Medal (1794) Legion of Honour <sup>[1]</sup> Order of the Iron Crown <sup>[1]</sup>

example: electric eel (“battery” in the water)



It generates large electric currents by way of a highly specialized nervous system that has the capacity to synchronize the activity of **disc-shaped, electricity-producing cells** packed into a specialized electric organ.

When an electric eel senses danger, it “turns itself into a living battery” – pushing out electrons with nearly double the energy of those from a mains socket (!)

# electric current

An electric current ( $I$ ) is a flow of electric charge. In electric circuits this charge is often carried by moving electrons in a wire. It can also be carried by ions in an electrolyte, or by both ions and electrons such as in a plasma.

It is a scalar quantity and it describes the amount of charge transferred in time:  $I = Q/t$  ( $Q$  – electric charge,  $t$  - time)

unit: ampere [A], one from the basic units of the SI system.

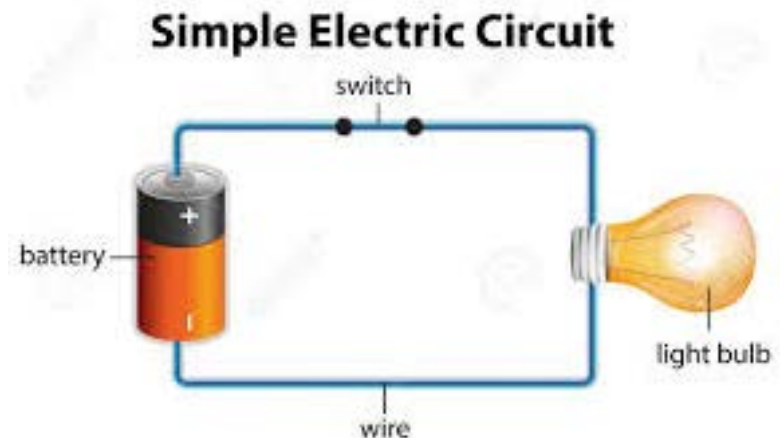
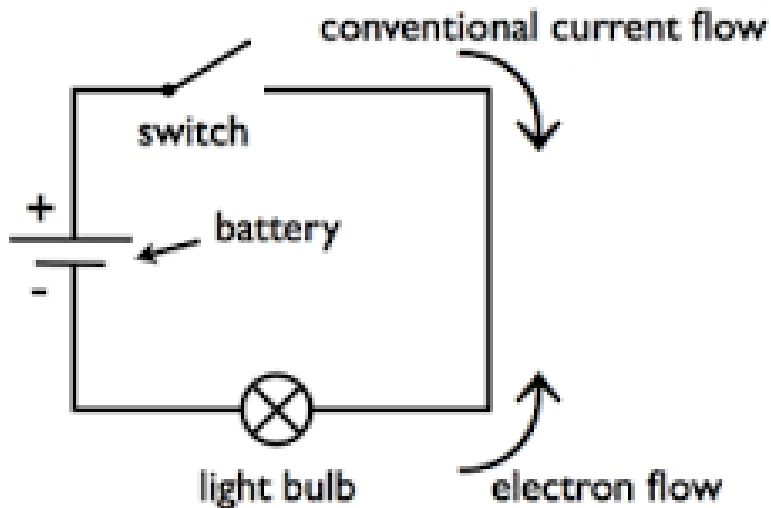

# Ampere:

## current definition:

1 ampere is a constant current which, if maintained in two straight parallel conductors of infinite length, of negligible circular cross-section, and placed 1 m apart in vacuum, would produce between these conductors a force equal  $2 \cdot 10^{-7}$  newtons per metre of length.

The problem is that newton is defined by means of kilogram, which will be also redefined.

## proposed definition (should be adopted in 2018):

1 A, is the unit of electric current; its magnitude is set by fixing the numerical value of the elementary charge to be equal to exactly  $1.602176 \cdot 10^{-19}$  when it is expressed in the unit A·s, which is equal to C.

# electric potential, electric field

Difference in electric potential between two points is known as **voltage**.

Electric field is a **vector quantity** ( $\vec{E}$ ):  $\vec{E} = -grad\phi = -\nabla\phi$  (called also intensity) – associates to each point in space the Coulomb force experienced by a unit electric charge (it points in the direction of an action on positive charge).

Unit:  $[V \cdot m^{-1}] = [kg \cdot m \cdot s^{-3} \cdot A^{-1}] = [kg \cdot m \cdot s^{-2} \cdot (A \cdot s)] = [N \cdot C^{-1}]$ .

# electric potential, electric field

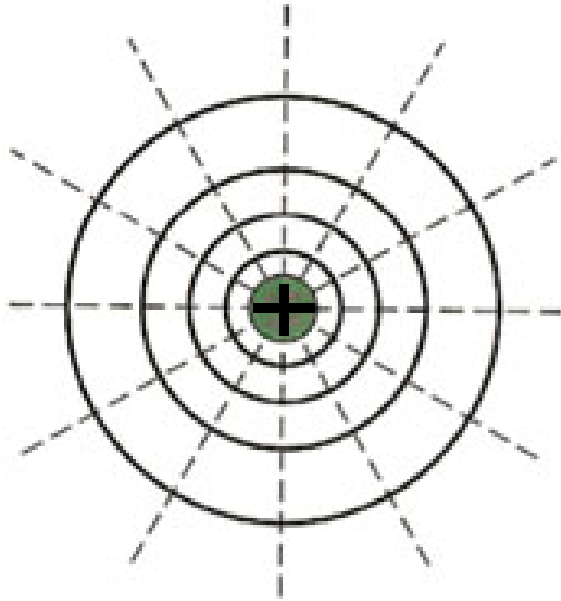

**equipotential lines** (surfaces)  
around an electric monopole  
(show places with constant  
value of potential)

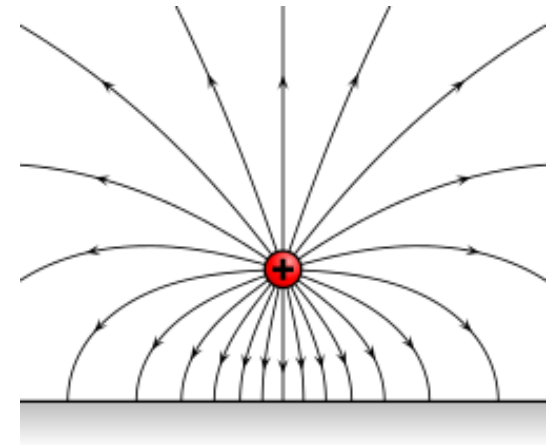
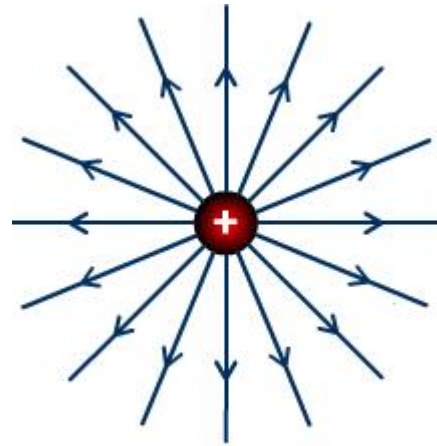

**lines of force (lines of field)**  
in the vicinity of an electric monopole  
(show lines of the electric force action  
– by convention they point in the  
direction of an action on positive charge)



# electric flux

Electric flux  $\Phi_E$  is the measure of flow of the electric field through a given area  $A$ .

For a planar area  $A$  we can write:

$$\Phi_E = \mathbf{E} \cdot \mathbf{S} = ES \cos \theta$$

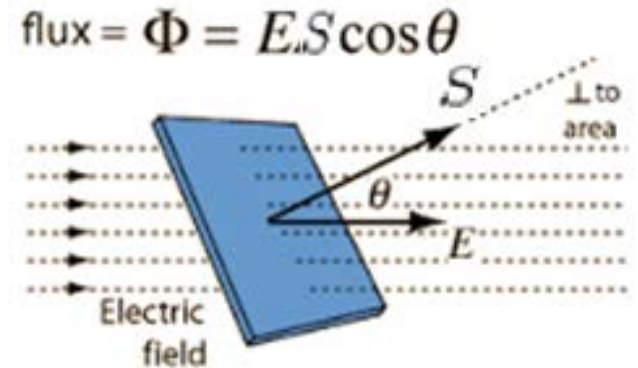

For an irregular area  $A$  we have to write an integral:

$$\Phi_E = \iint_S \mathbf{E} \cdot d\mathbf{S}$$

and for closed irregular area  $A$ :

$$\Phi_E = \oiint_S \mathbf{E} \cdot d\mathbf{S}$$

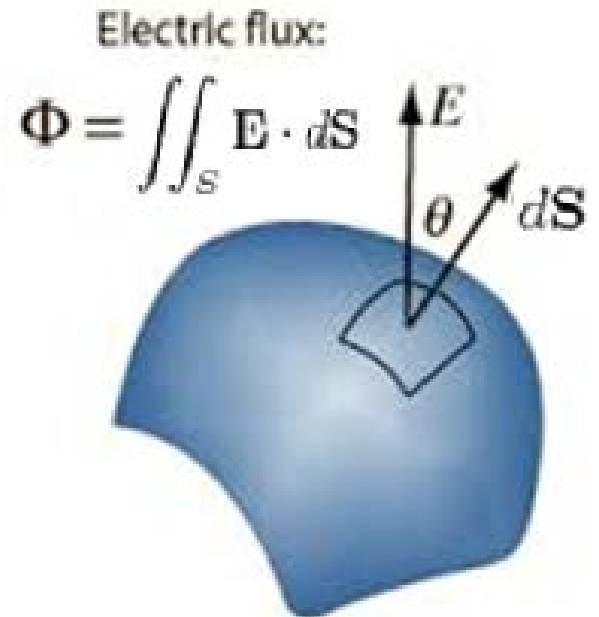

# electric current density

**Current density** ( $J$ ) is a quantity, which size is defined as the electric current ( $I$ ) per unit area of cross section ( $S$ ):

$$J = I / S,$$

unit: amperes per square metre [ $A \cdot m^{-2}$ ].

In some approaches it is defined as a vector quantity.

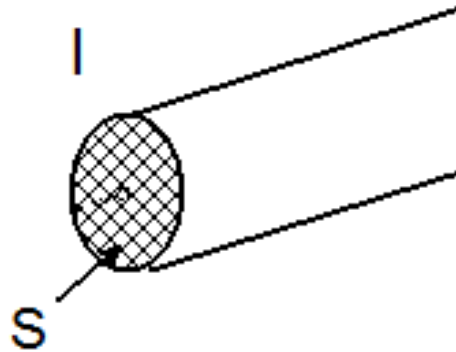

Evaluation of the total amount of charge ( $Q$ ) flowing through the surface  $S$  in a time interval ( $t_2 - t_1$ ):

$$Q = \int_{t_1}^{t_2} \left[ \iint_S \vec{J} \cdot d\vec{S} \right] dt$$

# comment on lightnings

power vs. energy (lecture nr. 2, connection to mechanical work)



Could we use captured lightnings to produce electrical power?

Unfortunately not, due to its very short duration (few  $\mu\text{sec}$ ), Its power can be very high (up to  $10^{11}$  W), but due to the mentioned short time of their existence the energy (work) is only on the level of  $10^7$  J, which correspond to approx. one day consumption of an old-fashioned 100 W light bulb.

# Lecture 5: electricity

## Content:

- introduction
- electric charge, potential, field and current
- electric dipole
- resistance, conductance, Ohm's law
- resistivity, conductivity
- Kirchhoff's circuit laws
- dielectric materials, permittivity
- capacitor, capacitance
- alternating current
- skin effect, dispersion

# electric dipole - potential

Develops by the attraction of two separate charges – positive and negative ones.

$$\varphi(P) = \frac{1}{4\pi\epsilon_0} \frac{\vec{m} \cdot \vec{r}}{r^3} = \frac{1}{4\pi\epsilon_0} \frac{\vec{m} \cdot \vec{r}}{r^2} = \frac{1}{4\pi\epsilon_0} \frac{m \cos \theta}{r^2}$$

where:

$\vec{m}$  is the dipole moment (unit: coulomb-meter [C·m]),

$\vec{r}$  the distance vector between the centre of the dipole and point P

( $\hat{r}$  is the unit vector in the direction of  $\vec{r}$ ),

$\theta$  the angle between  $\vec{m}$  and  $\vec{r}$ .

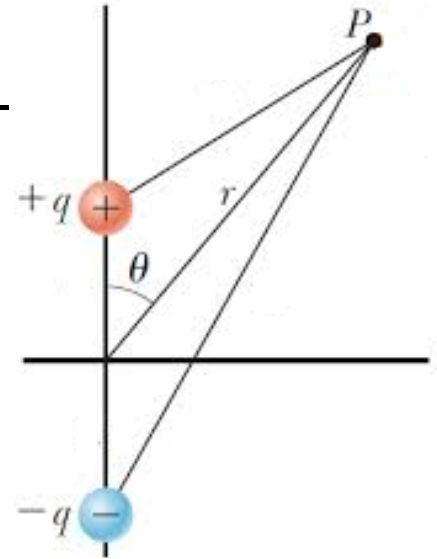

Dipole in an electric field

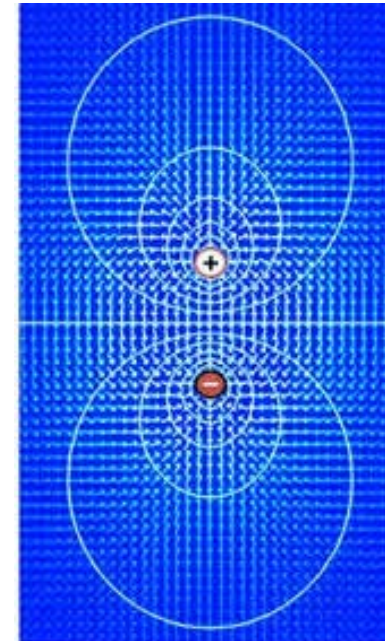
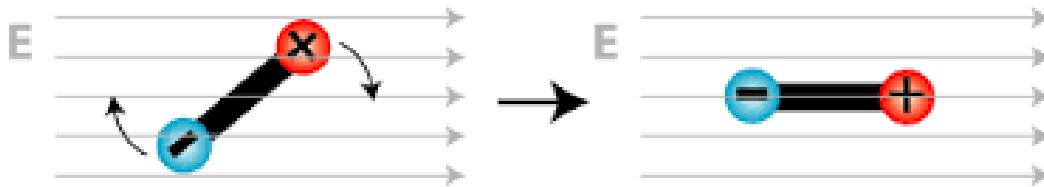

equipotential lines (surfaces)

# electric dipole – field (intensity)

$$\vec{E} = -\text{grad}\varphi = -\nabla\varphi = \dots$$

only to remember – unit:  $[\text{V}\cdot\text{m}^{-1}]$ .

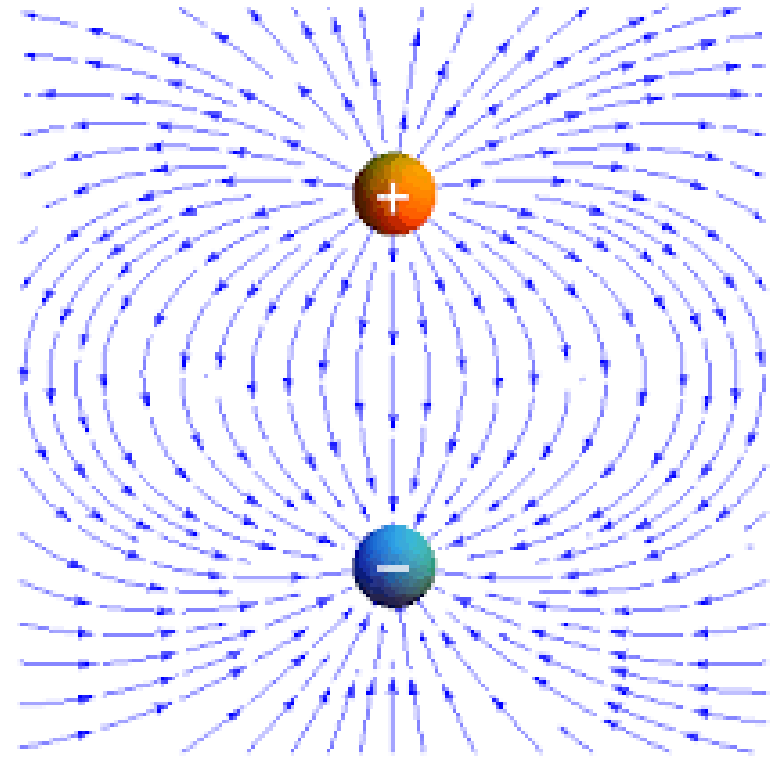
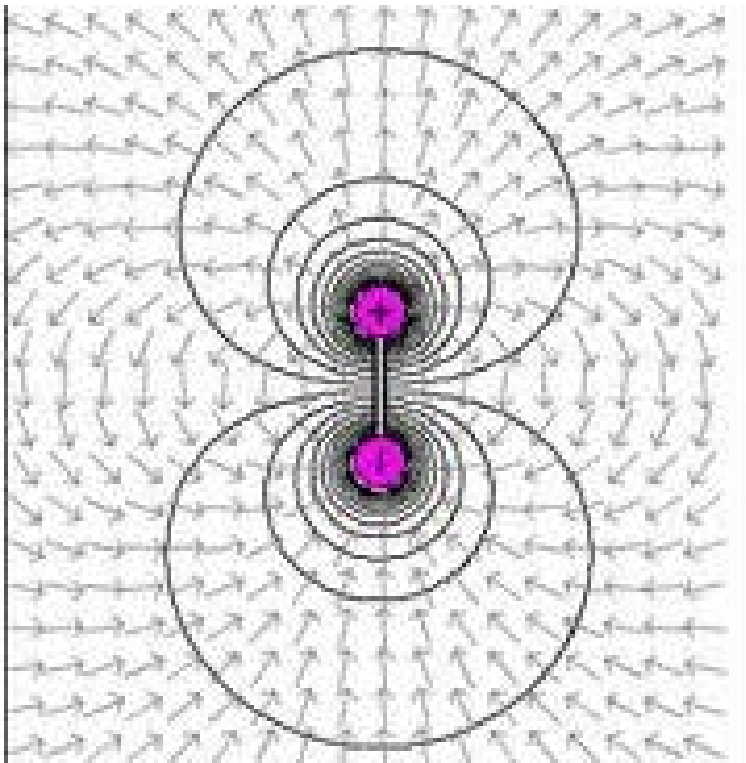

lines of force (lines of field)

# electric dipoles – in chemistry

Many molecules have such dipole moments **due to non-uniform distributions of positive and negative charges on the various atoms**. Such is the case with polar compounds like hydrogen fluoride (HF), where electron density is shared unequally between atoms.

**In a carbon monoxide molecule, the electron density near the carbon atom is greater than that near the oxygen, which result in a dipole moment.**

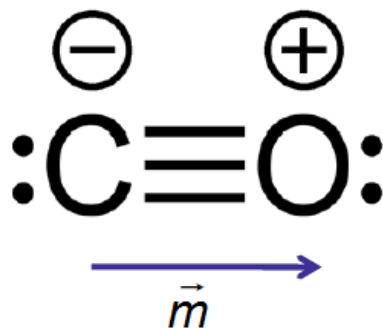

Dipole moment of carbon monoxide molecule is equal to 0.112 D (special unit debye is called after the physical chemist Peter J. W. Debye, 1 debey =  $3.33564 \cdot 10^{-30}$  C·m).

# electric dipoles – in chemistry

Some typical gas phase values in debye units are:

- carbon dioxide: 0
- carbon monoxide: 0.112 D
- ozone: 0.53 D
- phosgene: 1.17 D
- water vapor: 1.85 D
- hydrogen cyanide: 2.98 D
- cyanamide: 4.27 D
- potassium bromide: 10.41 D

Thanks to the fact that water molecules have a relatively strong residual dipole moment, water works very well as a solvent for other molecules that have both weak and strong dipole moments and ions.

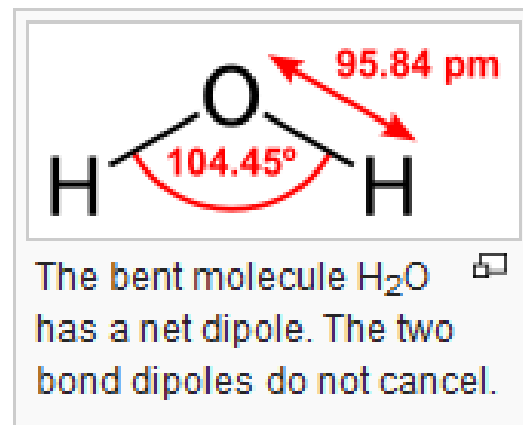
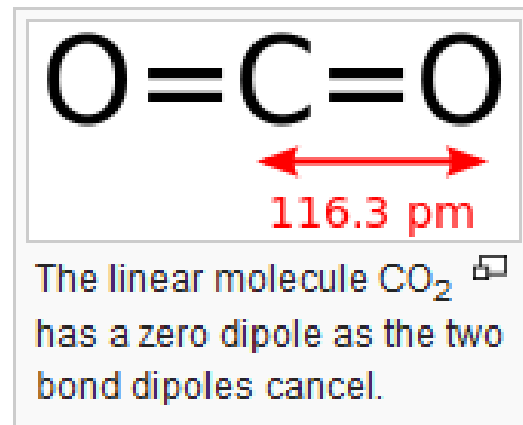



# electric dipoles – in biophysics

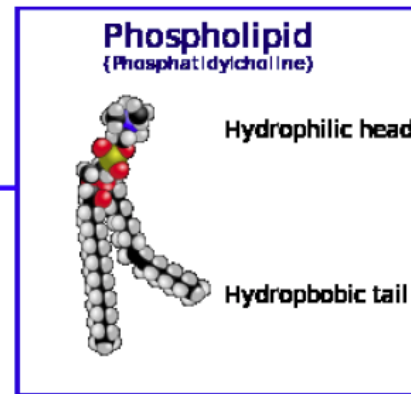
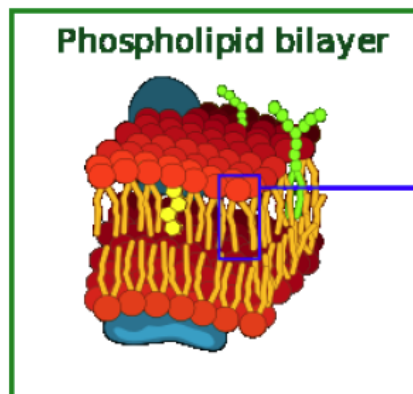
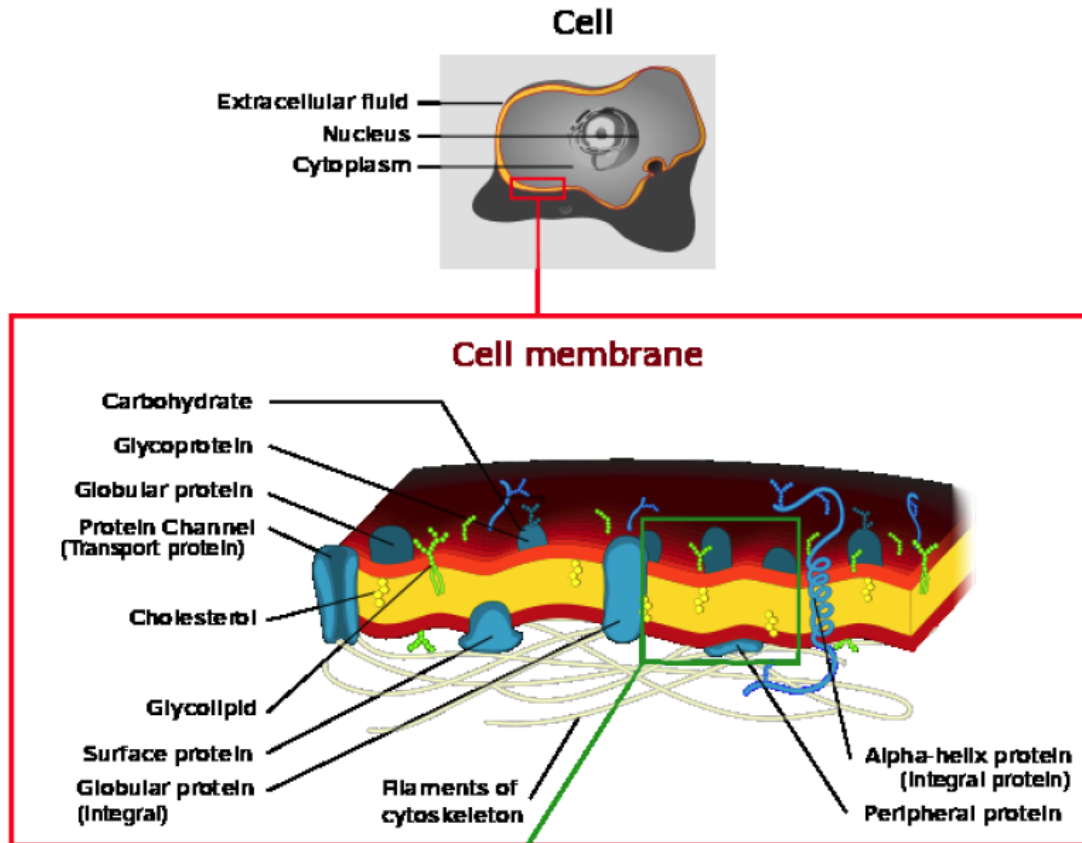

Polar  
(carries a dipole)

# Electrophoresis

Electrophoresis is the migration of charged particles, usually macromolecules, such as DNA and proteins, under the influence of an electric field. It is an analytical technique widely used to separate different macromolecules, typically by size or charge.

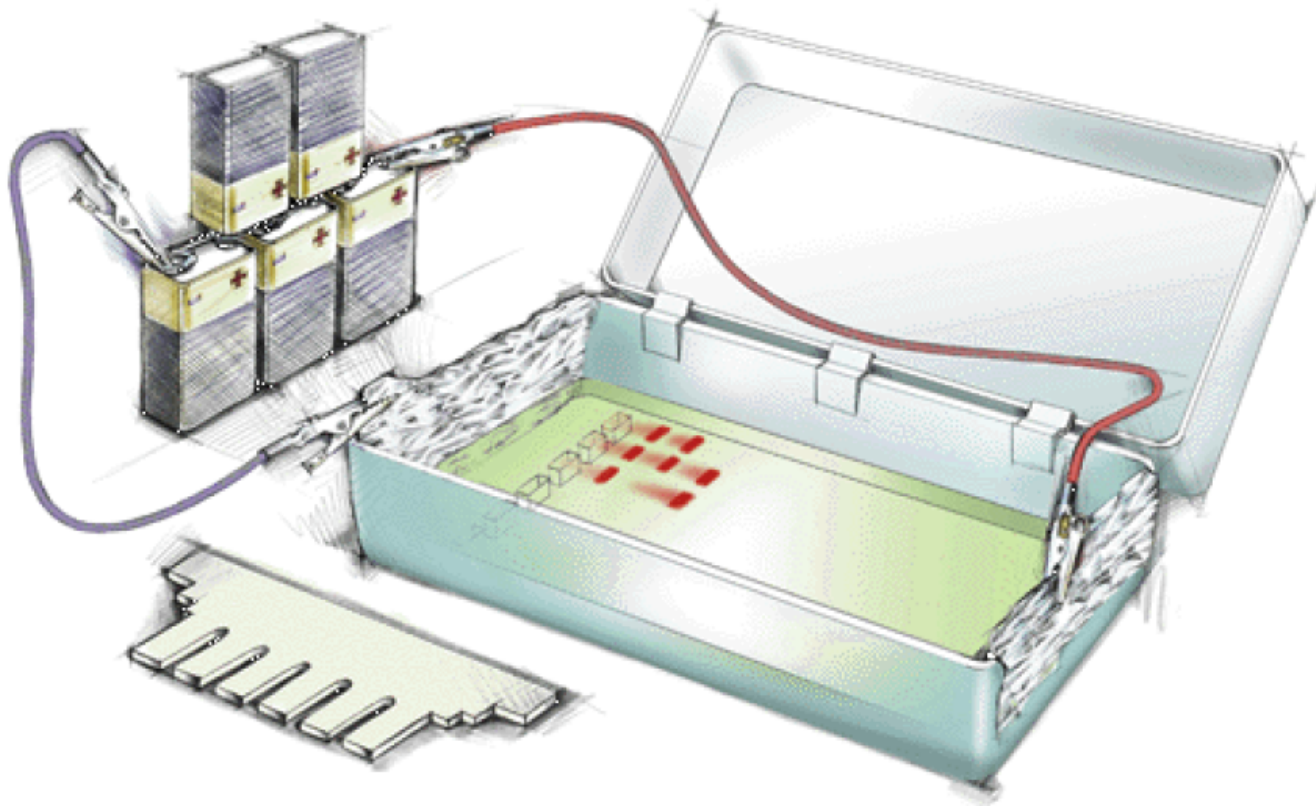

# Lecture 5: electricity

## Content:

- introduction
- electric charge, potential, field and current
- electric dipole
- resistance, conductance, Ohm's law
- resistivity, conductivity
- Kirchhoff's circuit laws
- dielectric materials, permittivity
- capacitor, capacitance
- alternating current
- skin effect, dispersion

# electrical resistance and conductance – Ohm's law

The **electrical resistance** ( $R$ ) of an electrical conductor is a measure of the difficulty to pass an electric current through that conductor.

Unit: Ohm,  $[\Omega] = [V/A] = [kg \cdot m^2 \cdot s^{-3} \cdot A^{-2}]$ .

It is given as the ration of voltage ( $U$ ) to current ( $I$ ), so called **Ohm's law**:

$$R = U/I$$

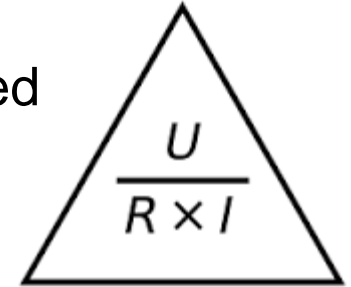

Electronical component (with a defined resistance) is called **resistor**.

Component	Resistance ( $\Omega$ )
1 meter of copper wire with 1 mm diameter	0.02
1 km overhead power line (typical)	0.03
AA battery (typical internal resistance)	0.1
Incandescent light bulb filament (typical)	200–1000
Human body	1000 to 100,000

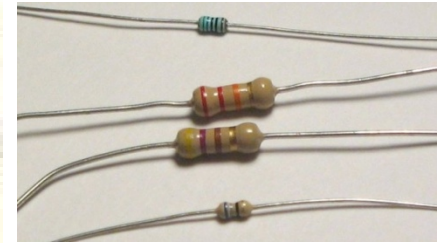
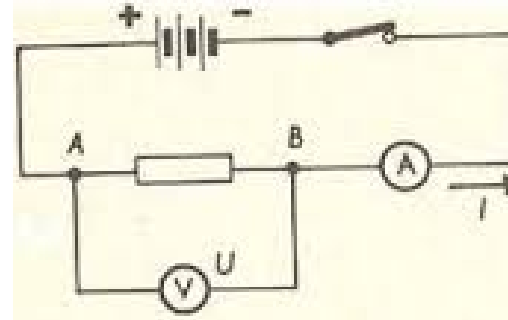

The inverse quantity to electrical resistance is **electrical conductance** ( $G$ ):

$$G = I/U = 1/R$$

Unit: siemens,  $[S] = [\Omega^{-1}] = [kg^{-1} \cdot m^{-2} \cdot s^3 \cdot A^2]$ .

# electrical resistance and conductance – Ohm's law

The **electrical resistance** ( $R$ ) of an electrical conductor is a measure of the difficulty to pass an electric current through that conductor.

Unit: Ohm,  $[\Omega] = [V/A] = [kg \cdot m^2 \cdot s^{-3} \cdot A^{-2}]$ .

It is given as the ration of voltage ( $U$ ) to current ( $I$ ), so called **Ohm's law**:

$$R = U/I$$

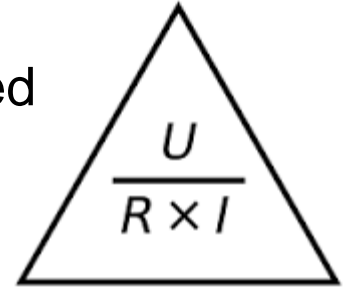

Ohm's law is a very good approximation for wires and resistors (assuming that other conditions, including temperature, are held constant).

Materials or objects where Ohm's law is true are called **ohmic**, whereas objects that do not obey Ohm's law are **non-ohmic** (diodes, batteries and other devices whose conductance is not constant.).



# electrical resistance – Joule heating

Electrical energy is dissipated (during passing an object with high resistance), **heating the resistor** in the process. This is called **Joule heating**, also called **ohmic heating** or **resistive heating**.

The formula for Joule heating is:

$$P = I^2 R$$

where  $P$  is the power (energy per unit time, unit is watt  $[W] = [J \cdot s^{-1}] = [kg \cdot m^2 \cdot s^{-3}]$ ) converted from electrical energy to thermal energy,  $R$  is the resistance, and  $I$  is the current through the resistor.

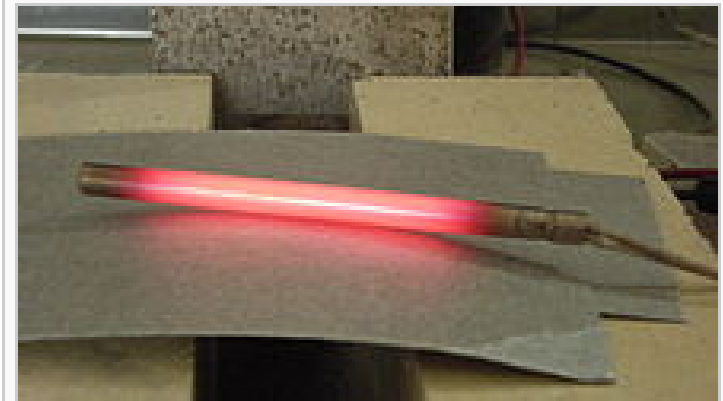

Running current through a material with high resistance creates heat, in a phenomenon called **Joule heating**. In this picture, a **cartridge heater**, warmed by **Joule heating**, is **glowing red hot**.

# electrical resistivity and conductivity

## Relation to resistivity and conductivity

The resistance of a given object depends primarily on two factors: what material it is made of, and its shape.

For a given material, the resistance is inversely proportional to the cross-sectional area and the length of it.

$$R = \rho \frac{\ell}{A},$$

$$G = \sigma \frac{A}{\ell}.$$

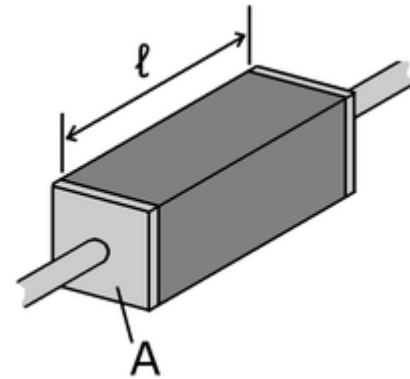

where  $\ell$  is the length of the conductor, measured in metres [m],  $A$  is the cross-sectional area of the conductor measured in square metres [m<sup>2</sup>],  $\sigma$  (sigma) is the **electrical conductivity** measured in siemens per meter (S·m<sup>-1</sup>), and  $\rho$  (rho) is the **electrical resistivity** (also called specific electrical resistance) of the material, measured in ohm-metres (Ω·m).

Resistivity and conductivity are reciprocals:  $\rho = 1/\sigma$ .

# electrical resistivity and conductivity

**electrical resistivity ( $\rho$ ):** express the resistance of material with unit area cross-section (1 m<sup>2</sup>) and unit length (1 m).

**electrical conductivity ( $\sigma$ ):** is the inverse quantity to electrical resistivity.

## Resistivity of some materials

Material	Resistivity / $\Omega\text{m}$
copper	$1.7 \times 10^{-8}$
aluminium	$2.7 \times 10^{-8}$
graphite	$8.0 \times 10^{-6}$
silicon	$2.3 \times 10^3$
quartz	$5.0 \times 10^{16}$

Material	Resistivity $\rho$ (ohm m)	
Silver	1.61	$\times 10^{-8}$
Copper	1.70	$\times 10^{-8}$
Aluminum	2.74	$\times 10^{-8}$
Tungsten	5.3	$\times 10^{-8}$
Iron	9.8	$\times 10^{-8}$
Platinum	10.4	$\times 10^{-8}$
Manganin	48.2	$\times 10^{-8}$
Lead	21	$\times 10^{-8}$
Mercury	96	$\times 10^{-8}$
Nichrome (Ni,Fe,Cr alloy)	100	$\times 10^{-8}$
Constantan	49	$\times 10^{-8}$
Carbon* (graphite)	3-60	$\times 10^{-5}$
Germanium*	1-500	$\times 10^{-3}$
Silicon*	0.1-60	...
Glass	1-10000	$\times 10^9$
Quartz (fused)	7.5	$\times 10^{17}$
Hard rubber	1-100	$\times 10^{13}$



# electrical resistivity and conductivity

Back to equipotential lines (dashed) and lines of field (solid):

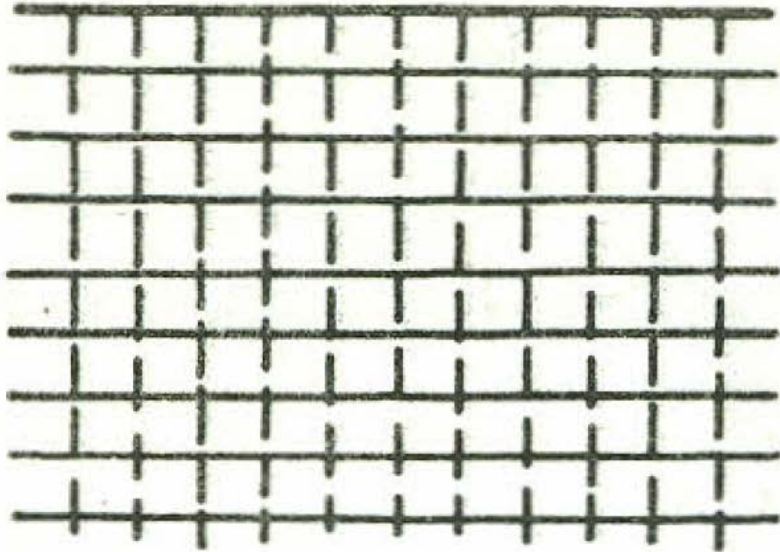

homogenous electrical field

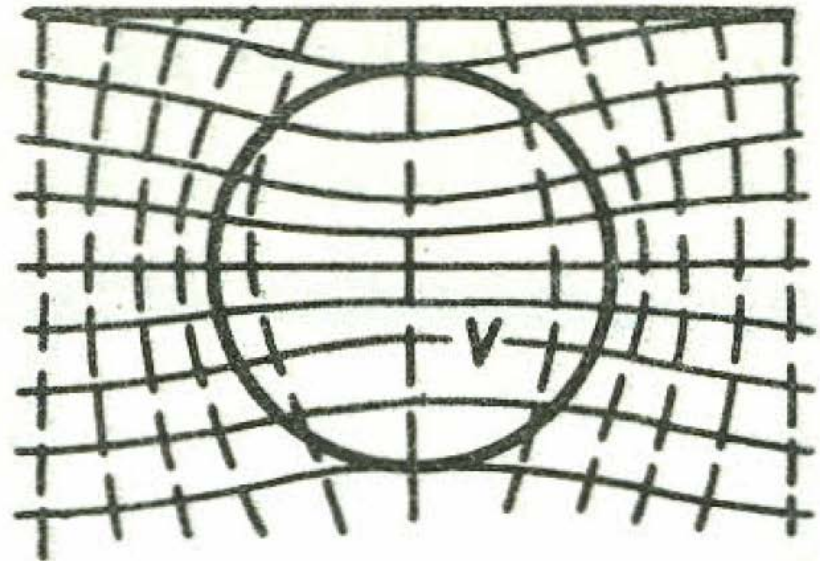

electrical field with a sphere

Question: is the sphere resistive or conductive?

Conductive.

## electrical resistivity and conductivity – back to Ohm's law

In some text-books and other materials, we can find a little bit different form of Ohm's law – the original form, formulated by Ohm:

$$\vec{J} = \sigma \vec{E}$$

where  $\mathbf{J}$  is the current density ( $\text{A}\cdot\text{m}^{-2}$ ),  $\sigma$  the electrical conductivity meter ( $\text{S}\cdot\text{m}^{-1}$ ) and  $\mathbf{E}$  the electric field ( $\text{V}\cdot\text{m}^{-1}$ ).

Or the form, which is often called as the **continuum equation**:

$$\vec{E} = \rho \vec{J}$$

where  $\rho$  is the electrical resistivity ( $\Omega\cdot\text{m}$ ).

# Lecture 5: electricity

## Content:

- introduction
- electric charge, potential, field and current
- electric dipole
- resistance, conductance, Ohm's law
- resistivity, conductivity
- Kirchhoff's circuit laws
- dielectric materials, permittivity
- capacitor, capacitance
- alternating current
- skin effect, dispersion

# Kirchhoff's circuit laws

Kirchhoff's circuit laws deal with the current and voltage in the elementary models of electrical circuits. They were first described in 1845 by German physicist Gustav Kirchhoff.

## 1. Kirchhoff's current law (KCL)

This law is also called Kirchhoff's first law, Kirchhoff's point rule, or Kirchhoff's junction rule (or nodal rule).

At any node (junction) in an electrical circuit, the sum of currents flowing into that node is equal to the sum of currents flowing out of that node.

In other words:

The algebraic sum of currents in a network of conductors meeting at a point is zero.

$$\sum_{k=1}^n I_k = 0$$

$n$  is the total number of branches with currents flowing towards or away from the node.

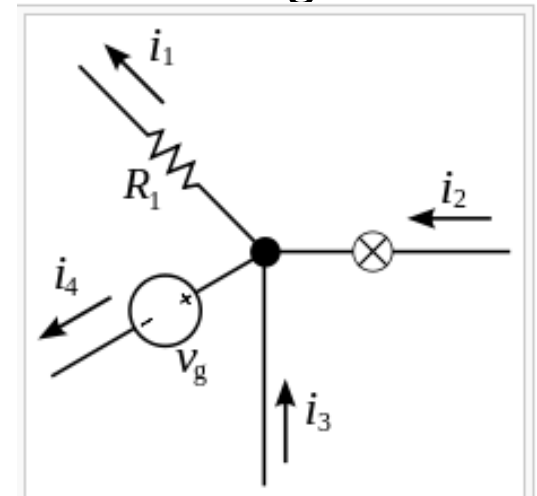

The current entering any junction is equal to the current leaving that junction.  $i_2 + i_3 = i_1 + i_4$

# Kirchhoff's circuit laws

Kirchhoff's circuit laws deal with the current and voltage in the elementary models of electrical circuits. They were first described in 1845 by German physicist Gustav Kirchhoff.

## 2. Kirchhoff's voltage law (KVL)

This law is also called Kirchhoff's second law, Kirchhoff's loop (or mesh) rule, and Kirchhoff's second rule.

The directed sum of the electrical potential differences (voltage) around any closed network is zero.

In other words:

The algebraic sum of individual voltages in a closed loop is zero.

$$\sum_{k=1}^n V_k = 0$$

$n$  is the total number of voltages measured.

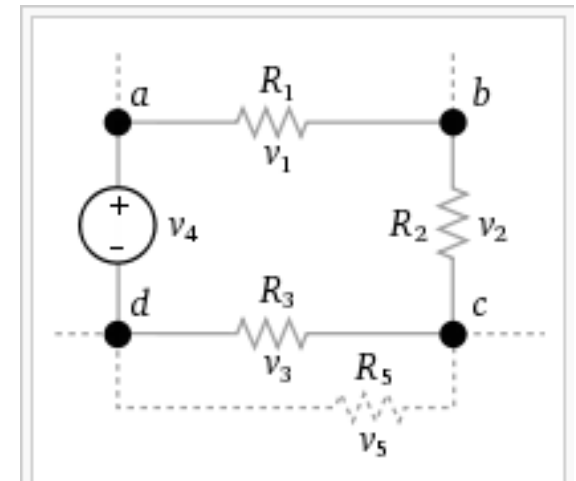

The sum of all the voltages around a loop is equal to zero.

$$v_1 + v_2 + v_3 - v_4 = 0$$

# Lecture 5: electricity

## Content:

- introduction
- electric charge, potential, field and current
- electric dipole
- resistance, conductance, Ohm's law
- resistivity, conductivity
- Kirchhoff's circuit laws
- dielectric materials, permittivity
- capacitor, capacitance
- alternating current
- skin effect, dispersion

# dividing materials based on their electrical properties

**Conductor:** In physics and electrical engineering, a conductor is an object or type of material that **allow the flow of electrical current** in one or more directions (mobile charged particles are electrons or ions).

**Metals are common electrical conductors.**

**Insulator** – is a material whose **internal electric charges do not flow freely**, and therefore make it nearly impossible to conduct an electric current under the influence of an electric field.

**Semiconductor** – is a crystalline or amorphous solid with distinct electrical characteristics. It is of high resistance (higher than typical resistance materials, but still of much lower resistance than insulators). It can pass the current in a special way - by means of the **movement of electrons and holes** (collectively known as "charge carriers") in their crystal structure.

**Dielectric material** – is an **electrical insulator that can be polarized by an applied electric field**. When a dielectric is placed in an electric field, electric charges do not flow through the material as they do in a conductor, but only slightly shift from their average equilibrium positions causing dielectric polarization.

# dividing materials based on their electrical properties

conductor:

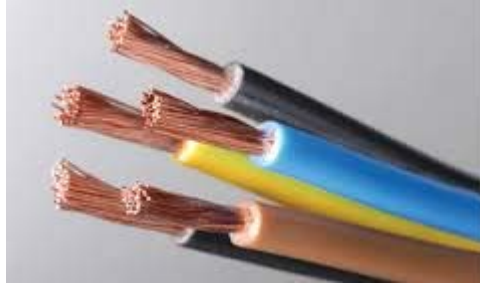

semiconductor:

List: [https://en.wikipedia.org/wiki/List\\_of\\_semiconductor\\_materials](https://en.wikipedia.org/wiki/List_of_semiconductor_materials)

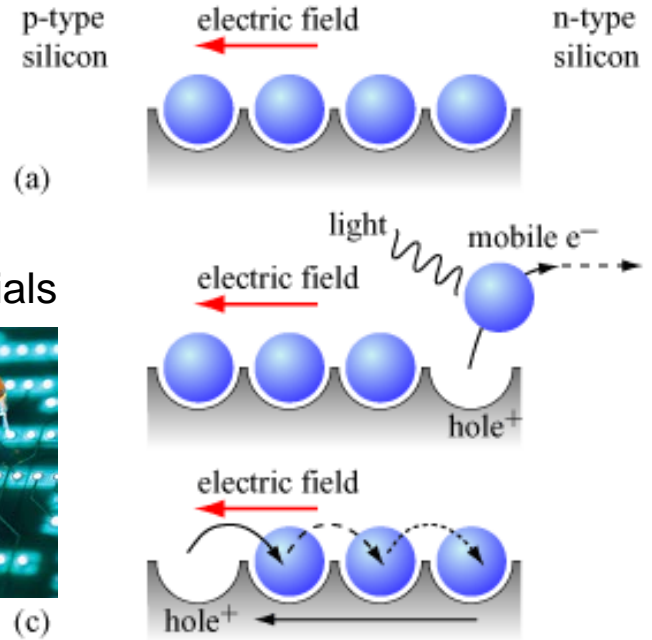

insulator:

Insulators : Non-conducting materials

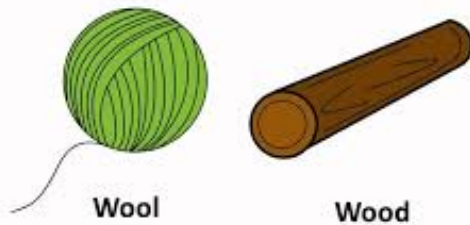



# dielectric material

A **dielectric material** (dielectric for short) is an **electrical insulator that can be polarized by an applied electric field**. When a dielectric is placed in an electric field, electric charges do not flow through the material as they do in a conductor, but only slightly shift from their average equilibrium positions causing dielectric polarization. The polarizability of a material is expressed by a number called the **relative permittivity  $\epsilon_r$**  (also known as **dielectric constant**) and **electric susceptibility  $\chi$** .

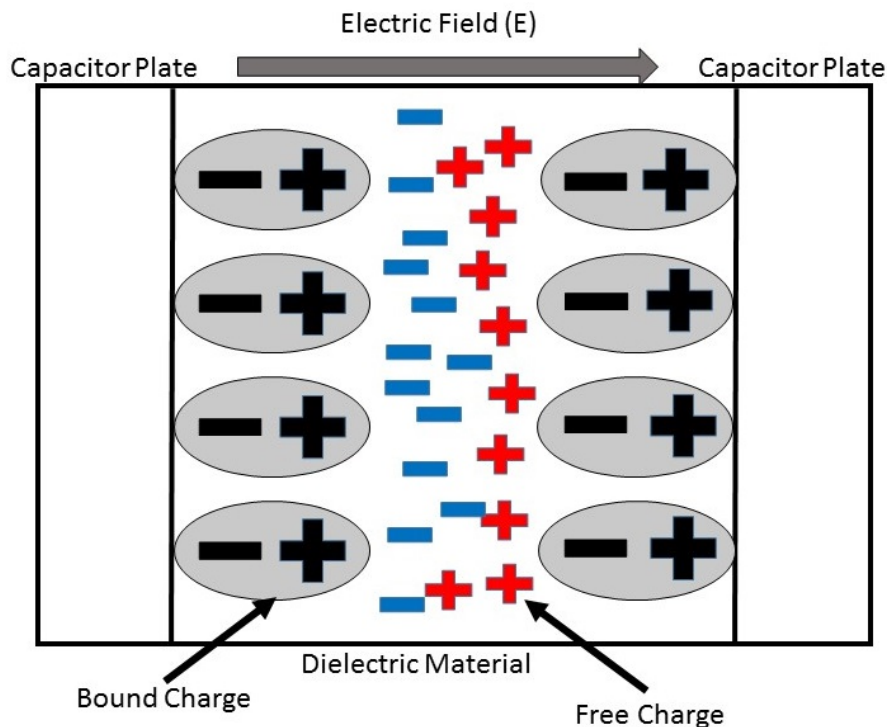

# comment: capacitor

A **capacitor** (originally known as a condenser) is a passive two-terminal electrical component used to store electrical energy temporarily in an electric field.

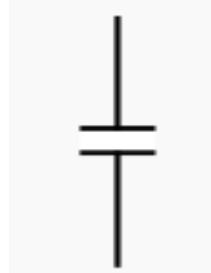

Its property to store an electrical charge is expressed by so called **electrical capacitance**, unit farad [F], named after the English physicist Michael Faraday. One farad is defined as the capacitance of a capacitor across which, when charged with one coulomb of electricity, there is a potential difference of one volt. Another explanation: the voltage across the two terminals of a 1 F capacitor will increase linearly by 1 V when a current of 1 A flows through it for 1 second.

$$F = \frac{A \cdot s}{V} = \frac{C}{V} = \frac{s^4 \cdot A^2}{m^2 \cdot kg}$$

# Faraday cage

A **Faraday cage** or **Faraday shield** is an enclosure formed by conductive material or by a mesh of such material, used to block electric fields. Faraday cages are named after the English scientist Michael Faraday, who invented them in 1836.

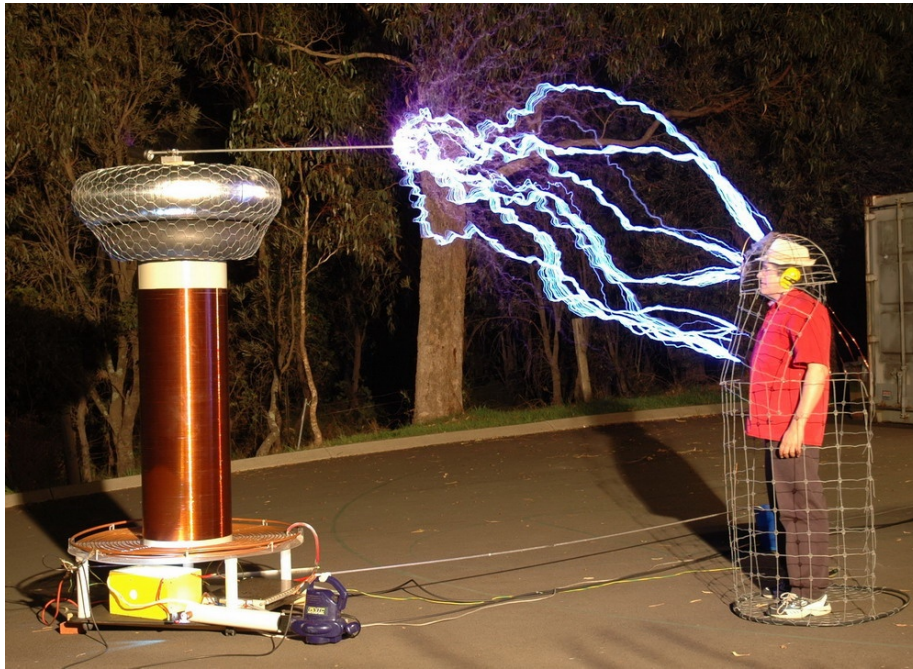

# dielectric material

**Permittivity**  $\epsilon$  is the measure of resistance that is encountered when forming an electric field in a medium. Unit: [F/m] = [A·s·V<sup>-1</sup>·m<sup>-1</sup>].

The permittivity of a medium describes how much electric field (more correctly, flux) is 'generated' per unit charge in that medium. More electric flux exists in a medium with a low permittivity (per unit charge) because of polarization effects. Permittivity is directly related to **electric susceptibility**  $\chi$ , which is a measure of how easily a dielectric polarizes in response to an electric field:

$$\epsilon = \epsilon_r \epsilon_0 = (1 + \chi) \epsilon_0$$

where  $\epsilon_r$  is the relative permittivity of the material, and

$\epsilon_0 = 8.8541878176 \cdot 10^{-12}$  F/m is the vacuum permittivity.

## Dielectric Constant of Materials

<b>Air</b>	<b>1.00</b>	<b>Paper</b>	<b>3.00</b>
<b>Alsimag 196</b>	<b>5.70</b>	<b>Plexiglass</b>	<b>2.80</b>
<b>Bakelite</b>	<b>4.90</b>	<b>Polyethylene</b>	<b>2.30</b>
<b>Cellulose</b>	<b>3.70</b>	<b>Polystyrene</b>	<b>2.60</b>
<b>Fiber</b>	<b>6.00</b>	<b>Porcelain</b>	<b>5.57</b>
<b>Formica</b>	<b>4.75</b>	<b>Pyrex</b>	<b>4.80</b>
<b>Glass</b>	<b>7.75</b>	<b>Quartz</b>	<b>3.80</b>
<b>Mica</b>	<b>5.40</b>	<b>Steatite</b>	<b>5.80</b>
<b>Mycalex</b>	<b>7.40</b>	<b>Teflon</b>	<b>2.10</b>

# Lecture 5: electricity

## Content:

- introduction
- electric charge, potential, field and current
- electric dipole
- resistance, conductance, Ohm's law
- resistivity, conductivity
- Kirchhoff's circuit laws
- dielectric materials, permittivity
- capacitor, capacitance
- alternating current
- skin effect, dispersion

# alternating current

In general, when current or voltage do not change their values with the time, they are called as **stationary fields** – e.g.  $I$ ,  $\varphi$ .

In the case of the current it is called as **direct current** (DC).

When there is a change, then we speak about **non-stationary fields (variable fields)** –  $I(t)$ ,  $\varphi(t)$ .

A special case of non-stationary current is the so called **alternating current** (AC). It is an electric current in which the flow of electric charge periodically reverses direction, whereas in direct current, the flow of electric charge is only in one direction.

The usual waveform of alternating current in most electric power circuits is a sine wave. In certain applications, different waveforms are used, such as triangular or square waves (or pulsating waves).

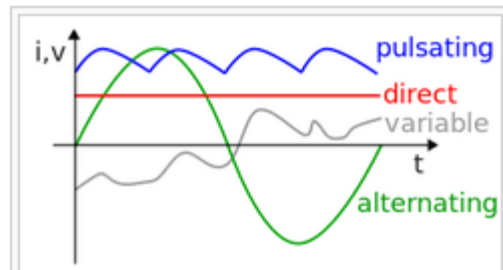

Alternating current (green curve).   
The horizontal axis measures time;  
the vertical, current or voltage.

# alternating current

The frequency of the electrical system varies by country and sometimes within a country; most electric power is generated at either **50 or 60 hertz**.

In some European rail systems (such as in Austria, Germany, Norway, Sweden and Switzerland), there is still used the older **16.7 Hz** power (formerly  $16 \frac{2}{3}$  Hz).

There existed special motors for **25 Hz** power (some industrial customers still exist in US).



Comment: The hertz (symbol Hz) is the unit of frequency in the SI system and is defined as one cycle per second [ $\text{Hz} = \text{s}^{-1}$ ].

# alternating current and voltage

## Mathematics of AC voltages

Alternating currents are accompanied (or caused) by alternating voltages.

An AC voltage  $v$  can be described mathematically as a function of time

by the following equation:

$$v(t) = V_{\text{peak}} \cdot \sin(\omega t),$$

where

- $V_{\text{peak}}$  is the peak voltage (unit: volt),
- $\omega$  is the angular frequency (unit: radians per second)
  - The angular frequency is related to the physical frequency,  $f$  (unit = hertz), which represents the number of cycles per second, by the equation  $\omega = 2\pi f$ .
- $t$  is the time (unit: second).

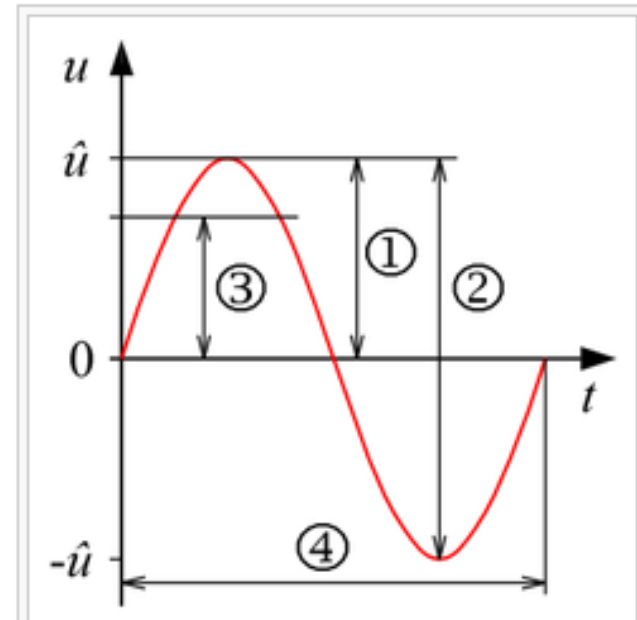

A sinusoidal alternating voltage. 

1 = peak, also amplitude,

2 = peak-to-peak,

3 = effective value,

4 = Period



# alternating current – impedance and admittance

Describing the properties of electric circuits in the case of alternating currents we need little bit more sophisticated tools – like impedance.

**Impedance**  $Z$  is the measure of the opposition that a circuit presents to a current when a voltage is applied.

It is a complex quantity, where the real part of impedance is the **resistance**  $R$  and the imaginary part is the **reactance**  $X$ :

$$Z = R + iX .$$

Also the Ohm's law gets a little bit different form:

$$V = IZ .$$

**Admittance** is the inverse quantity to impedance:

Admittance is defined as

$$Y \equiv \frac{1}{Z}$$

where  $Y$  is the admittance, measured in **siemens**

$Z$  is the impedance, measured in **ohms**

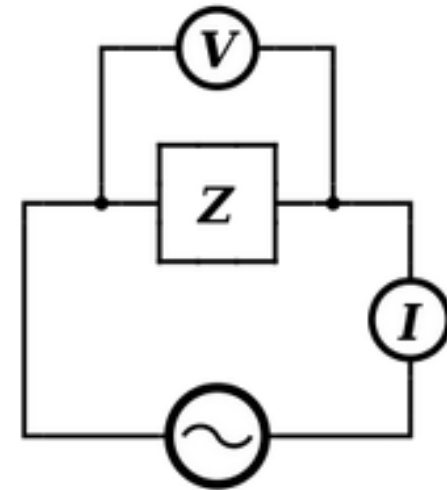

# alternating current – skin effect

Skin effect is the tendency of an alternating electric current (AC) to become distributed within a conductor such that the **current density is largest near the surface of the conductor**, and decreases with greater depths in the conductor. The electric current flows mainly at the "skin" of the conductor, between the outer surface and a level called the skin depth.

The skin effect causes the effective resistance of the conductor to increase **at higher frequencies where the skin depth is smaller**, thus reducing the effective cross-section of the conductor.

At 60 Hz in copper, the skin depth is about 8.5 mm. At high frequencies the skin depth becomes much smaller.

CURRENT PENETRATION DEPTH IN STEEL (CURRENT SHOWN IN BLUE)

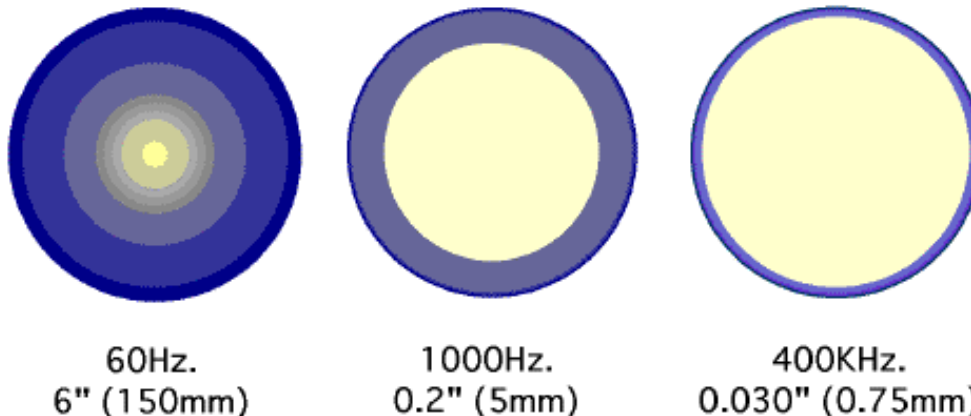

# alternating current – dielectric dispersion

Dielectric dispersion is the dependence of the permittivity of a dielectric material on the frequency of an applied electric field.

Because there is a lag between changes in polarization and changes in the electric field, the permittivity of the dielectric is a complicated function of frequency of the electric field.

Dielectric dispersion is very important for the applications of dielectric materials and for the analysis of polarization systems.

example:

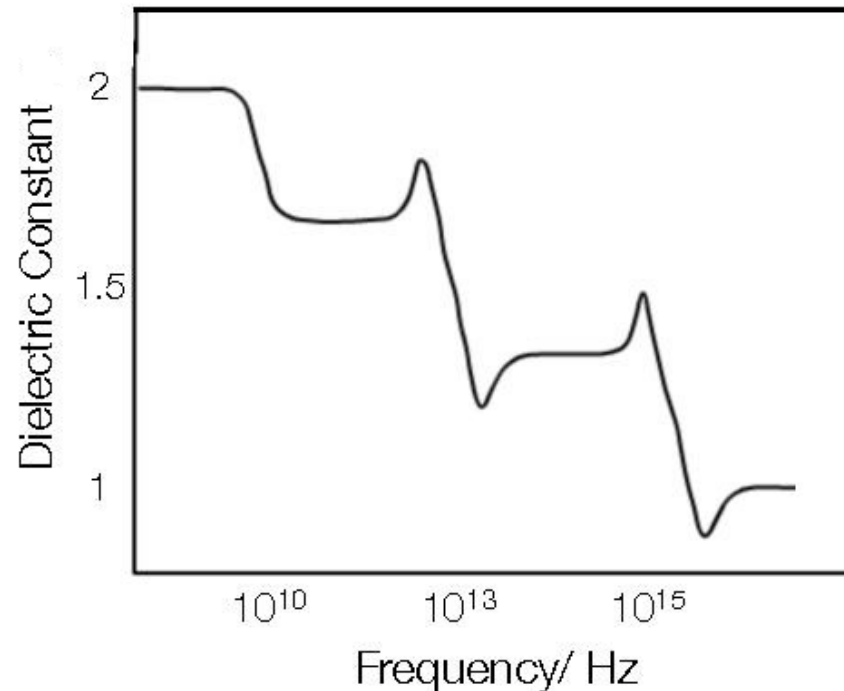

## DC vs. AC

Do you know these two important personalities from the area of electricity utilisation?

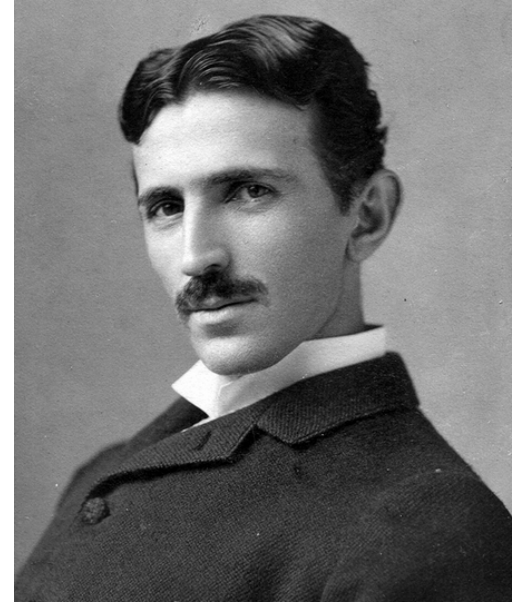
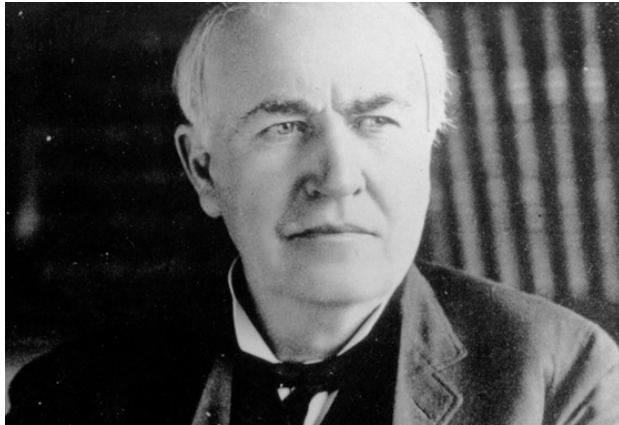

# DC vs. AC

Do you know these two important personalities from the area of electricity utilisation?

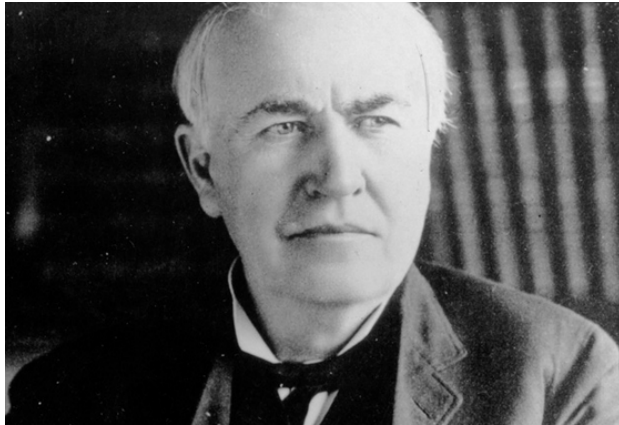

**Thomas Alva Edison**

11th February 1847, Milan, Ohio, USA –  
18th October 1931, West Orange, New Jersey, USA

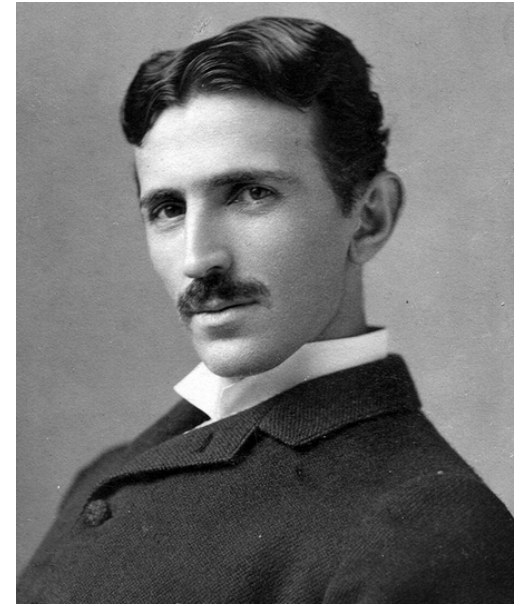

**Nikola Tesla**

10th July 1856, Smiljan, Austrian monarchy  
(today Croatia) –  
7th January 1943, New York, USA

good video showing in a simple form the difference between DC and AC:

<https://www.youtube.com/watch?v=BcIDRet787k>

Interesting reading about the “war of currents”:

[https://en.wikipedia.org/wiki/War\\_of\\_Currents](https://en.wikipedia.org/wiki/War_of_Currents)