

## Topic 10: light, optics

### Content:

- introduction to optics
- reflection VS refraction
- geometrical optics, lenses, mirrors
- microscope
- electron microscope, laser
- black body radiation
- units: lumen, lux, candela

# Optics

Optics is the branch of physics which involves the behaviour and properties of light, including its interactions with matter and the construction of instruments that use or detect it.

Optics usually describes the behaviour of visible, ultraviolet, and infrared light. Because light is an electromagnetic wave, other forms of electromagnetic radiation such as X-rays, microwaves, and radio waves exhibit similar properties.

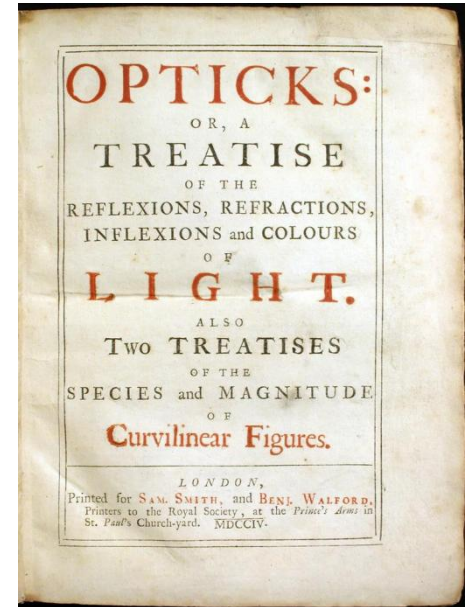
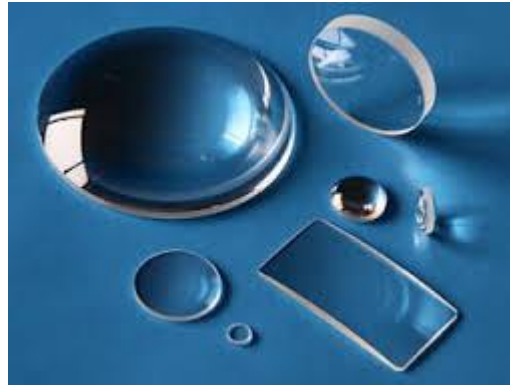

Cover of the first edition of Newton's Opticks.

# Optics

Different directions in optics:

- geometrical optics,
- wave optics,
- electromagnetic optics,
- quantum optics.



**Geometrical optics** (**ray optics**) describes the propagation of light in terms of "rays" which travel in straight lines, and whose paths are governed by the laws of **reflection** and **refraction** at interfaces between different media.

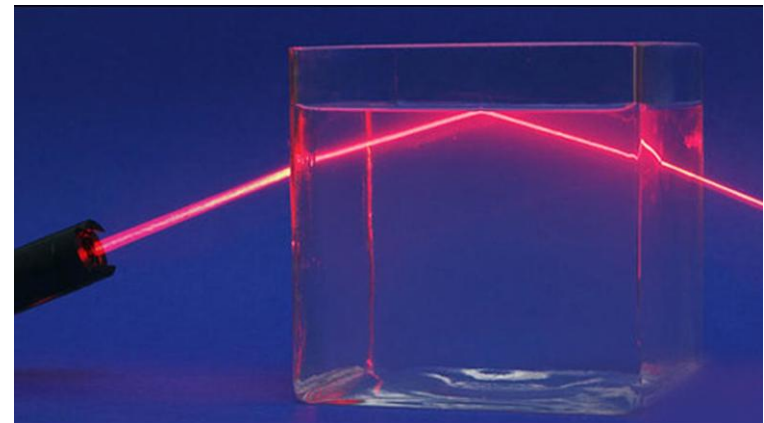
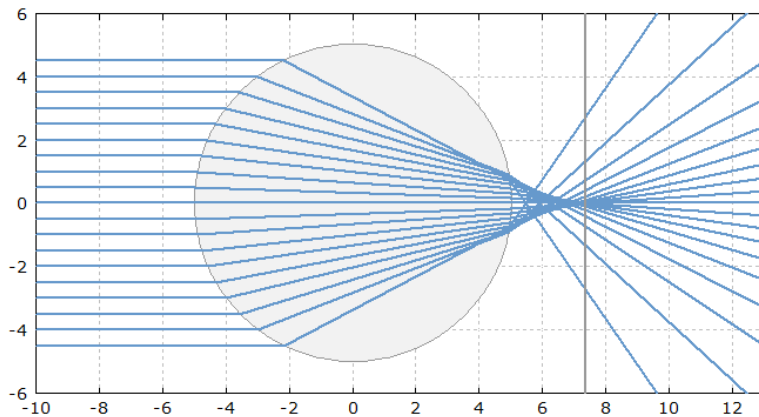

# EM waves

Changing electric and magnetic fields create an EM wave:

- electric field creates a magnetic field component,
- magnetic field creates an electric field component.

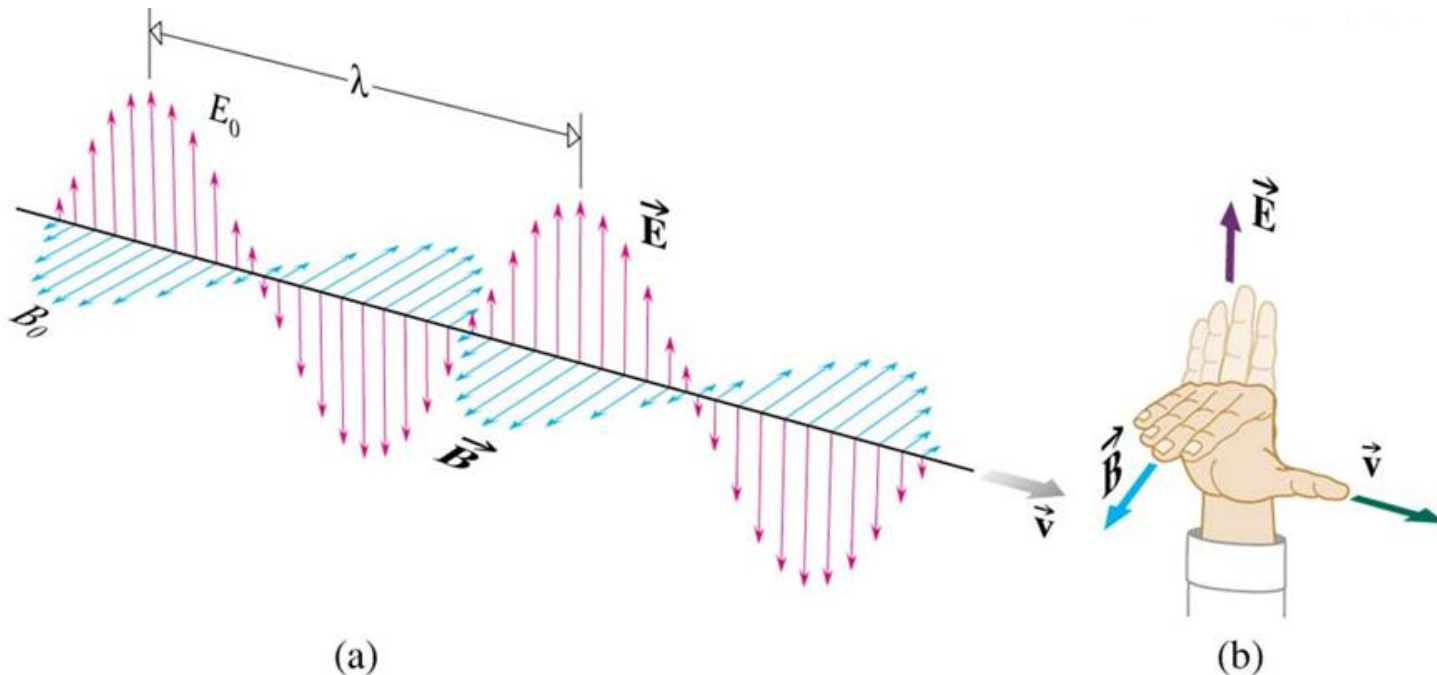

EM waves can have various wavelengths (frequencies).  
They can carry energy and information.

# EM waves spectrum

$$c = \lambda \cdot f$$

$\lambda$  - wavelength  
 $f$  - frequency

Visible light is only a part of this spectrum

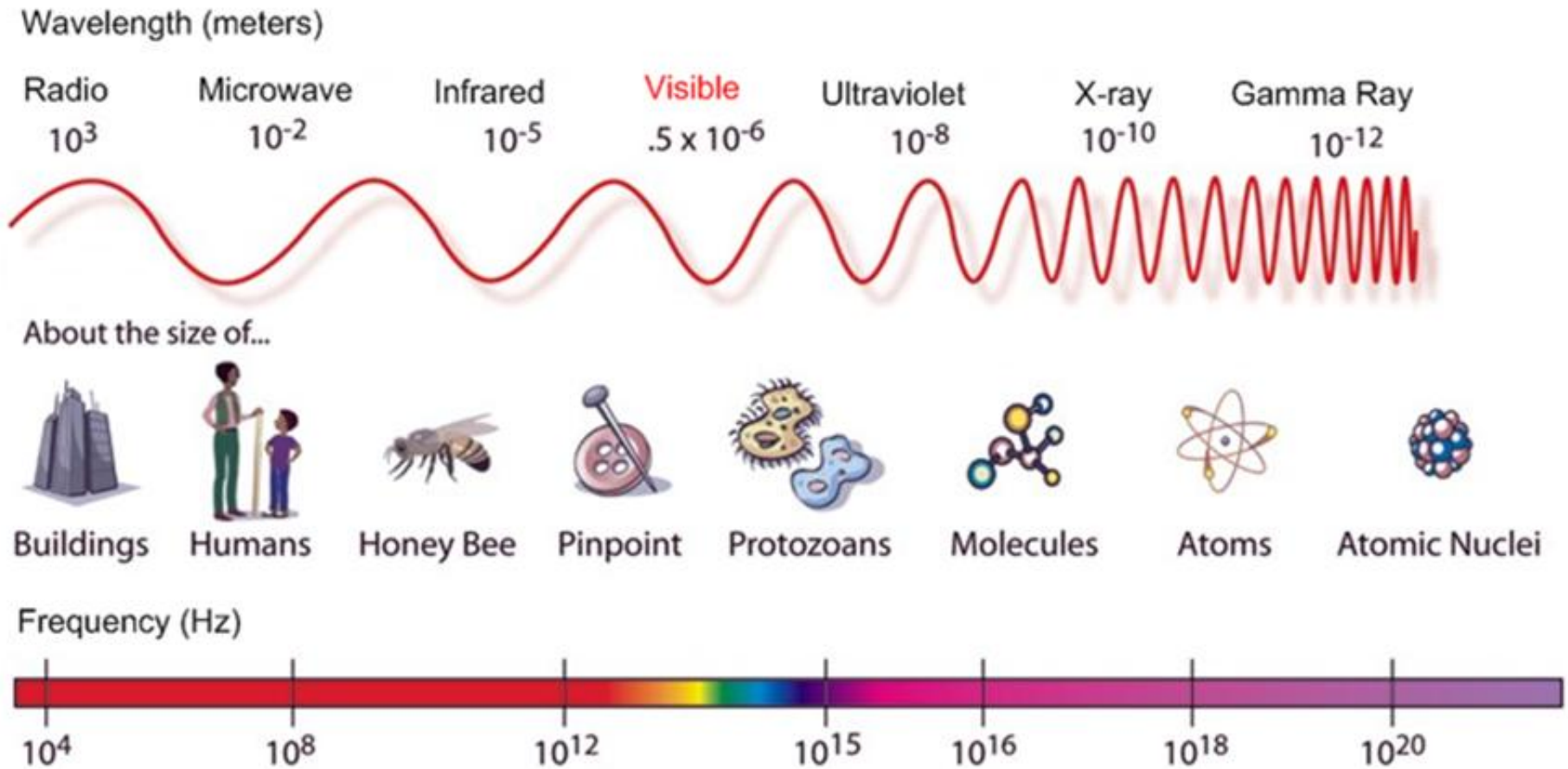

A good video from NASA: <https://www.youtube.com/watch?v=cfXzwh3KadE>

# visible light spectrum

$$c = \lambda \cdot f$$

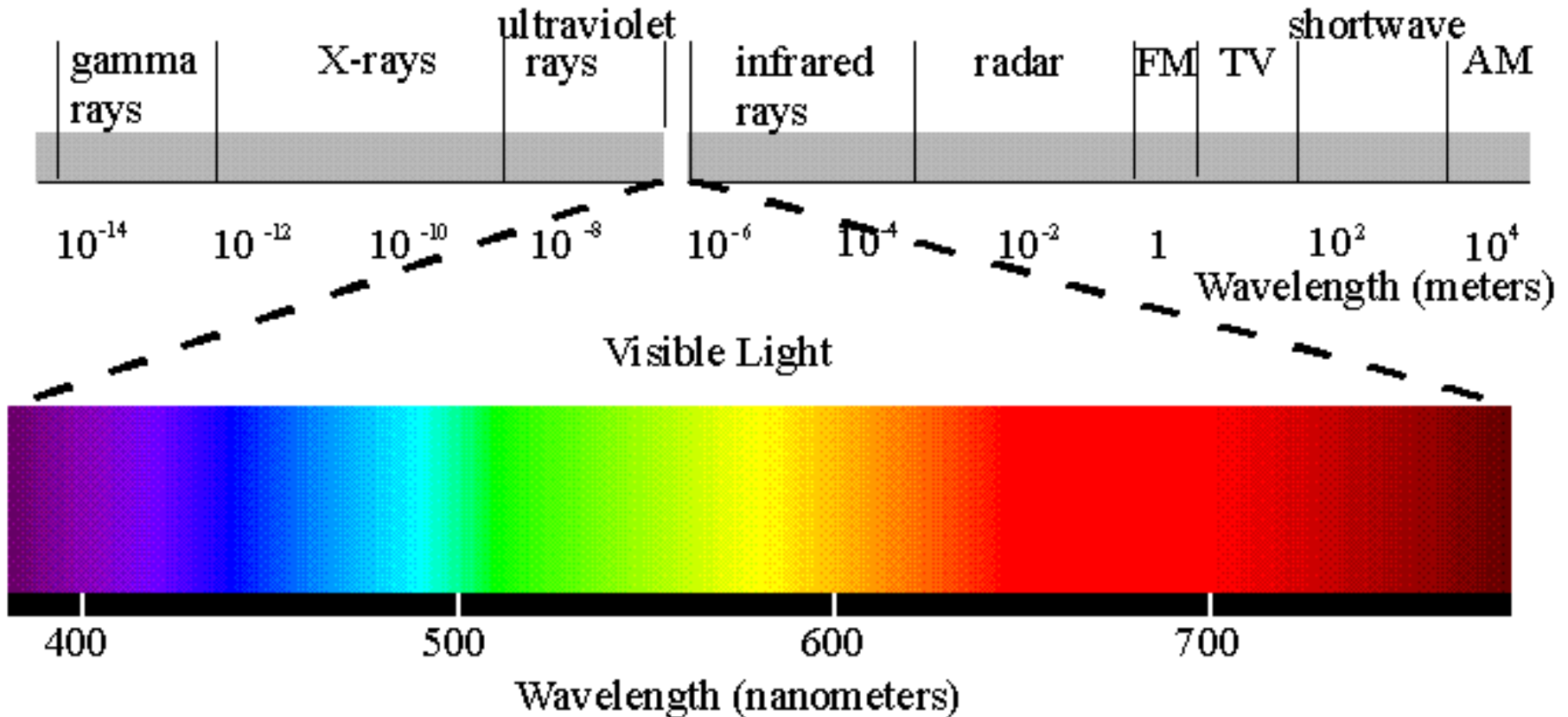

A typical human eye will respond to wavelengths from about 400 to 780 nm.

In terms of frequency, this corresponds to a band in the vicinity of 380–750 THz.

# visible light spectrum

Visible Light

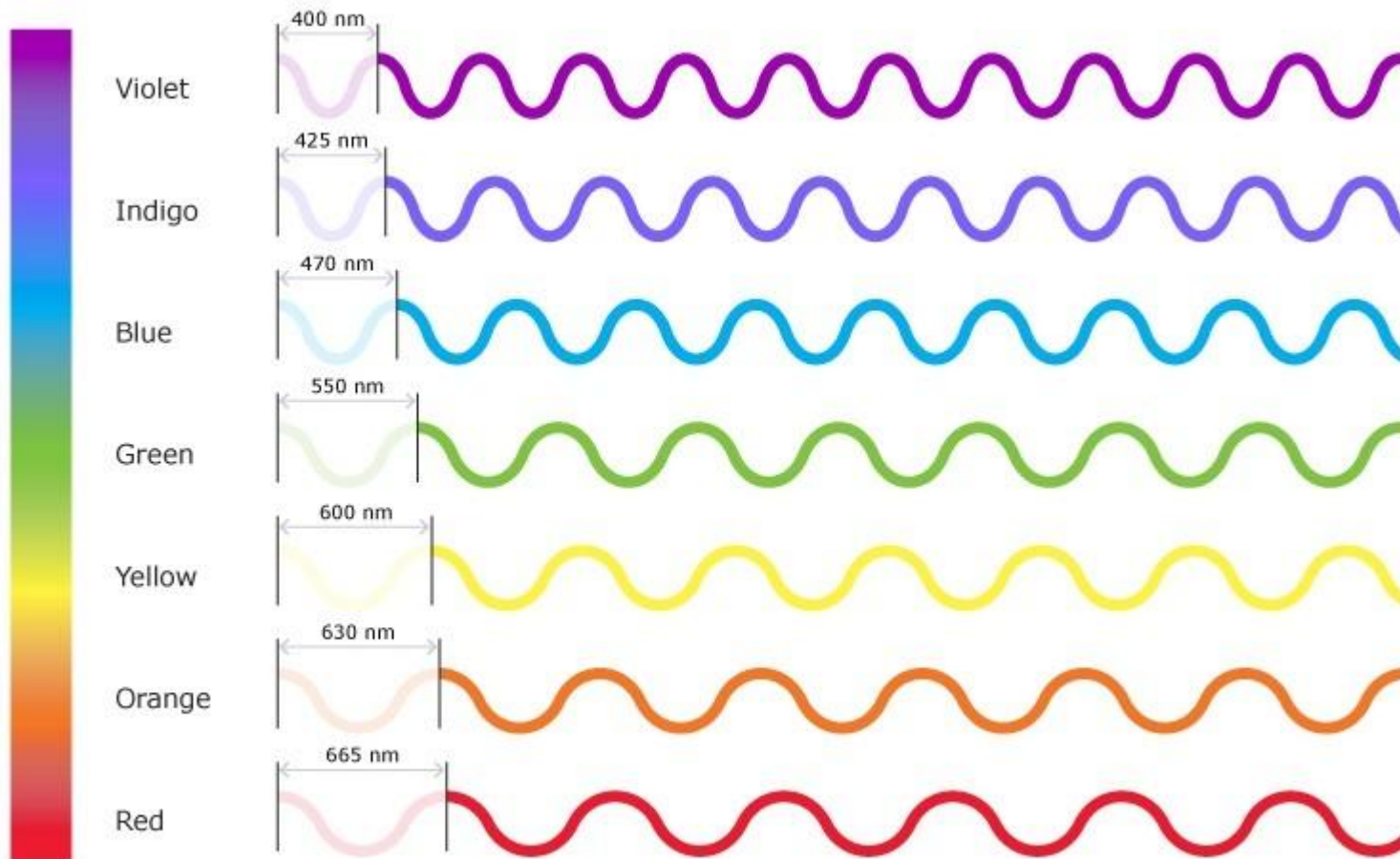
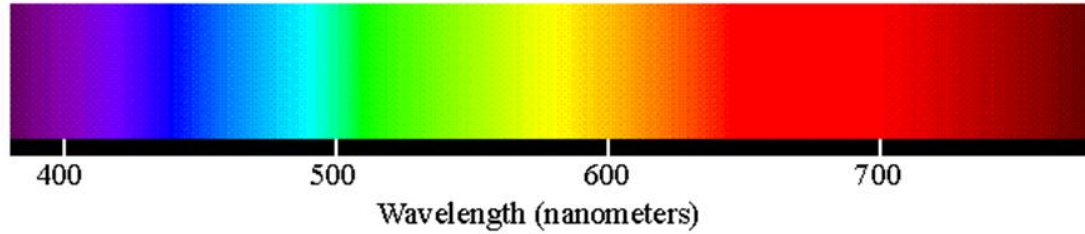

# visible light spectrum (refraction of light through a prism)

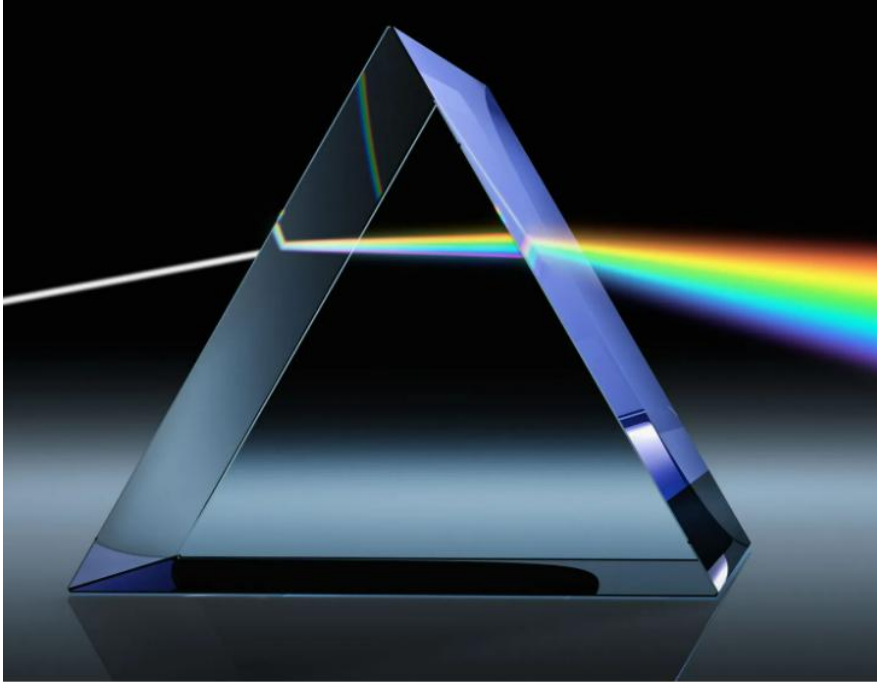

White light entering a prism is bent, or refracted, and the light separates into its constituent wavelengths.

Each wavelength of light has a different colour and bends (refracts) at a different angle.



The same phenomenon occurs in the case of a rainbow.

# Seeing things

Not everything does emit radiation. How do we see things?

- when waves run into a boundary they are partially **transmitted (refracted)** and partially **reflected** (light too),
- therefore, an object does not need to emit waves (photons) itself to be seen, it just has to reflect light back to our eyes where we can detect it,
- objects that do not allow light to pass through them are called **opaque**,
- objects that allow light to pass through them are considered **transparent**,
- objects in between are called **translucent**.

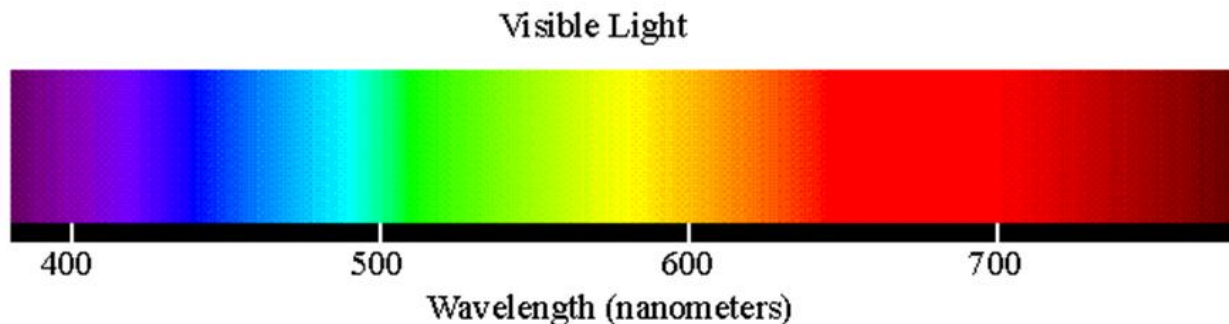

# Seeing things

- the light we see is know as **visible or white light**,
- the light is not really white, the white we see is a combination of **all the colours of the rainbow**,
- when all of these light waves are combined we see **white** light (all wavelengths are reflected back to our eyes),
- if we see something as RED or BLUE?
  - it reflected only the RED or only the BLUE wavelengths, the others were absorbed,
- and if we see something as **black**?
  - it did not reflect back any of the light.



# Seeing things

## Additive colours

Light from the **three additive primary colours** (**red**, **blue** and **green** - RGB) may be combined to make any other colour. This is used all the time in technology such as computer screens and televisions.

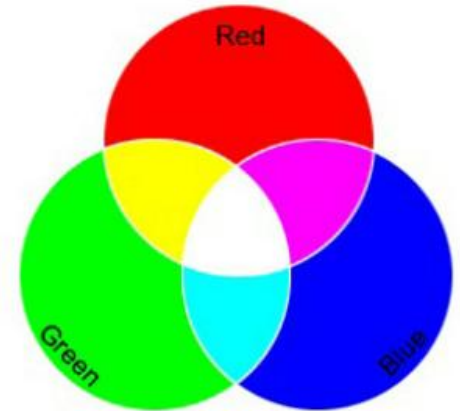

## Subtractive colours

If we have white light and want to subtract colours to get any other colour, we would use the **primary subtractive colours** (**cyan**, **magenta** and **yellow** - CMY) to filter or remove light of certain colours.

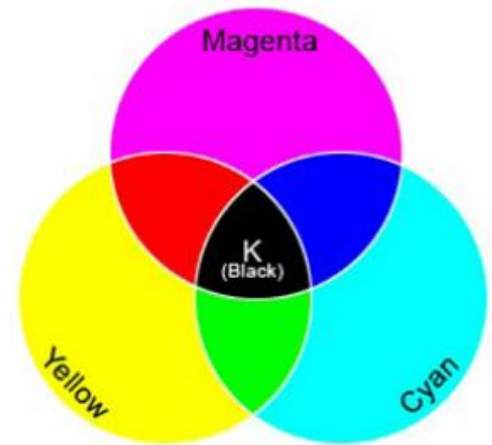

# visible light spectrum – edges on both sides (ultraviolet and infrared)

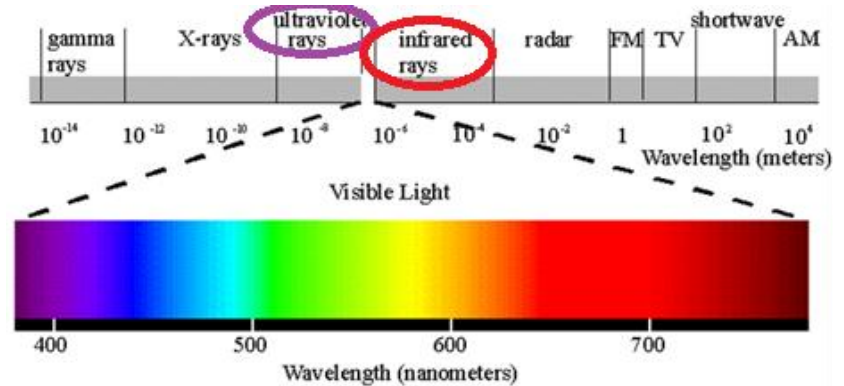

## Ultraviolet sensors:

Example (SONY sensor):

<https://www.sony-semicon.com/en/technology/industry/uv.html>

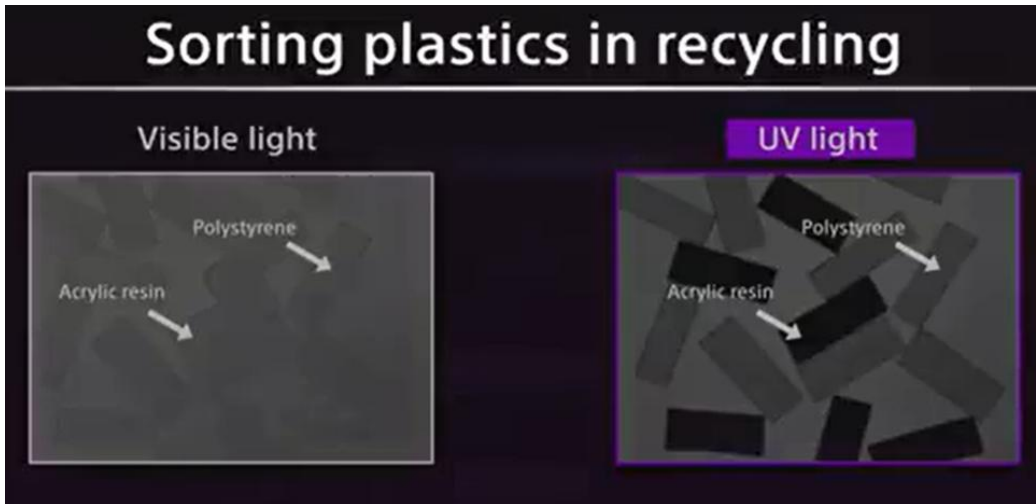

## Infrared cameras:

return of the NASA mission ARTEMIS II.

(infrared camera from approx. 15:00):

<https://www.youtube.com/watch?v=6uOqqPupSyA>



# Sources of light

## Natural and artificial

Natural: The Sun (stars), lightning, fire (natural fires), bioluminescent creatures (e.g. fire-fly), volcanic activity,

Artificial: fire (man-made), light bulbs, torches, LEDs, lasers, halogen lamps, screens, fireworks, glowsticks, matches, candle, petroleum lamp, gas lamp...

Natural Light

Natural light sources are those which are not man-made.

  
SUN

  
STARS

  
FIRE-FLY

Artificial light sources are man-made.  
They include candles; lamps and matches

  
LAMP

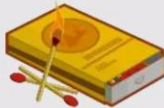
  
MATCHES

  
FIRE-FLY

# Sun

Source of light (and heat) in the sun is its core - the hottest part of the Sun. Nuclear reactions here (fusion) – where hydrogen is fused to form helium. Temperatures top 15 million °C.

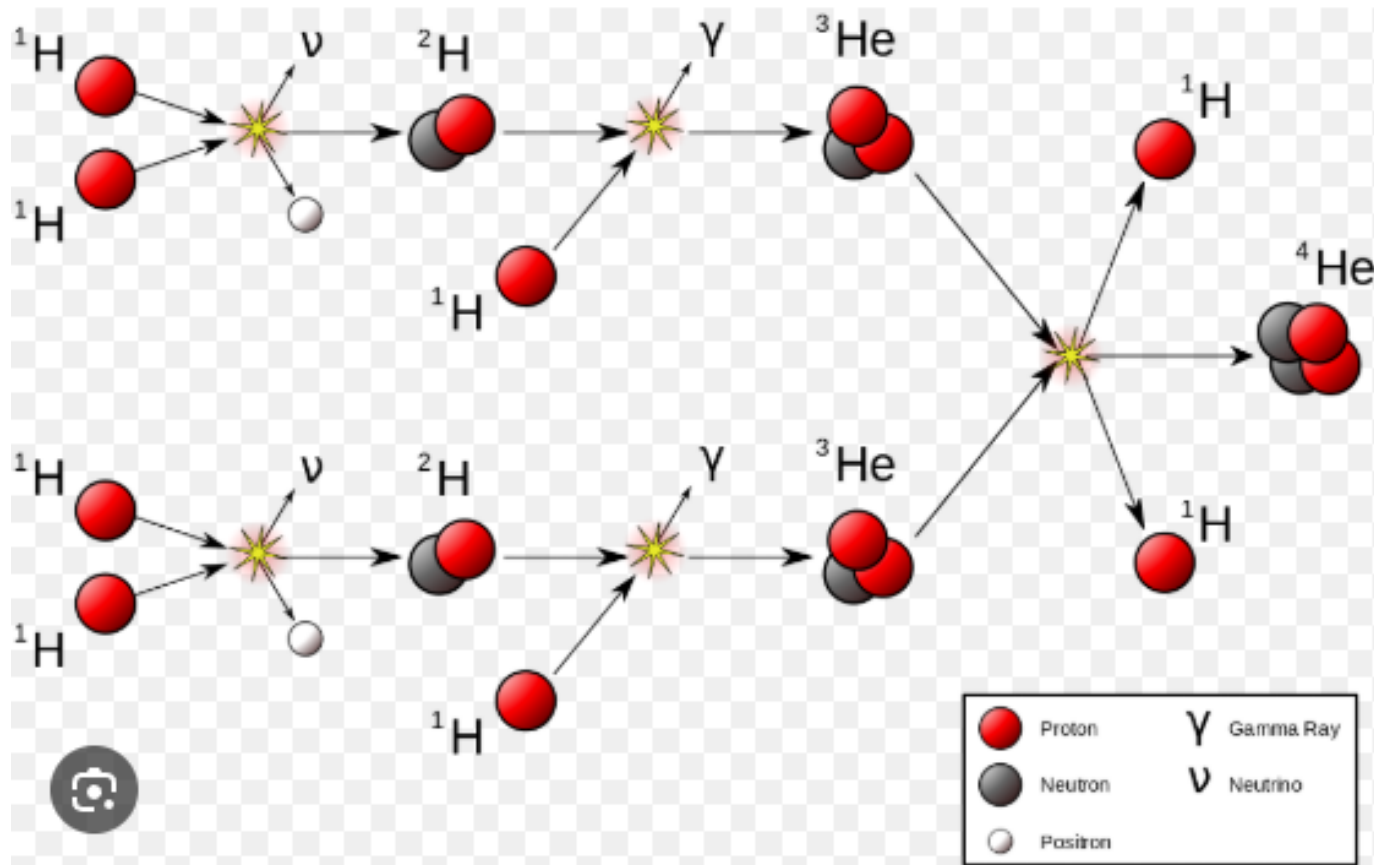

(two isotopes of hydrogen:  $^1\text{H}$  and  $^2\text{H}$  (deuterium); and two isotopes of helium:  $^3\text{He}$  and  $^4\text{He}$ )

# light bulb

Called as an **incandescent light bulb**, also known as an **incandescent lamp** or **incandescent light globe**

(incandescent = emitting light as a result of being heated)

Working principle:

passing of electric current through a thin wire called a filament, causing it to heat up and glow.

History:

Though **Thomas Edison** is usually credited as the man who invented the lightbulb, the famous American inventor wasn't the only one who contributed to the development of this revolutionary technology.

**Alessandro Volta**, **Humphrey Davy** and **Joseph Swan** played a critical role in the development of this technology.

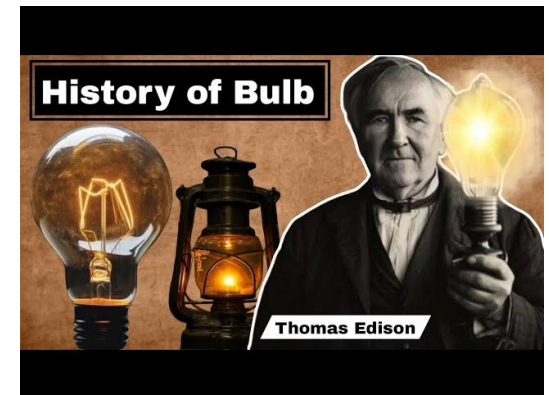
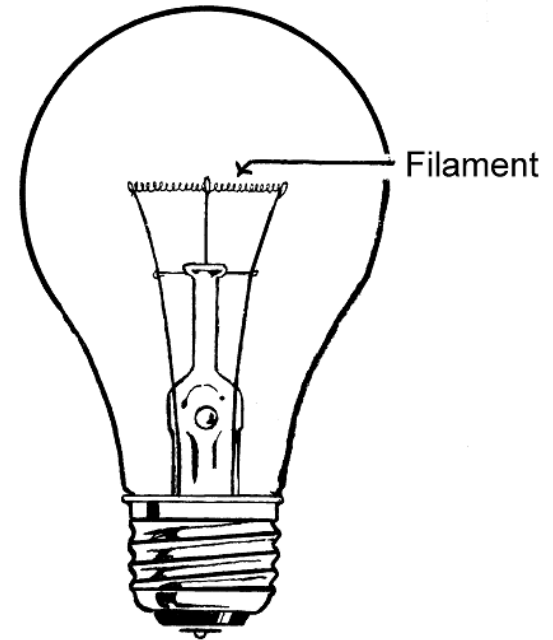

## light bulb

The spectrum of the light bulb spreads across 380-780 nm;  
- it produces the full range of the colour spectrum, carrying both visible and invisible colour wavelengths of light.

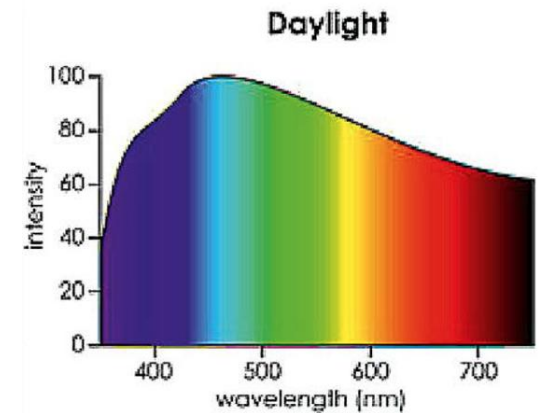
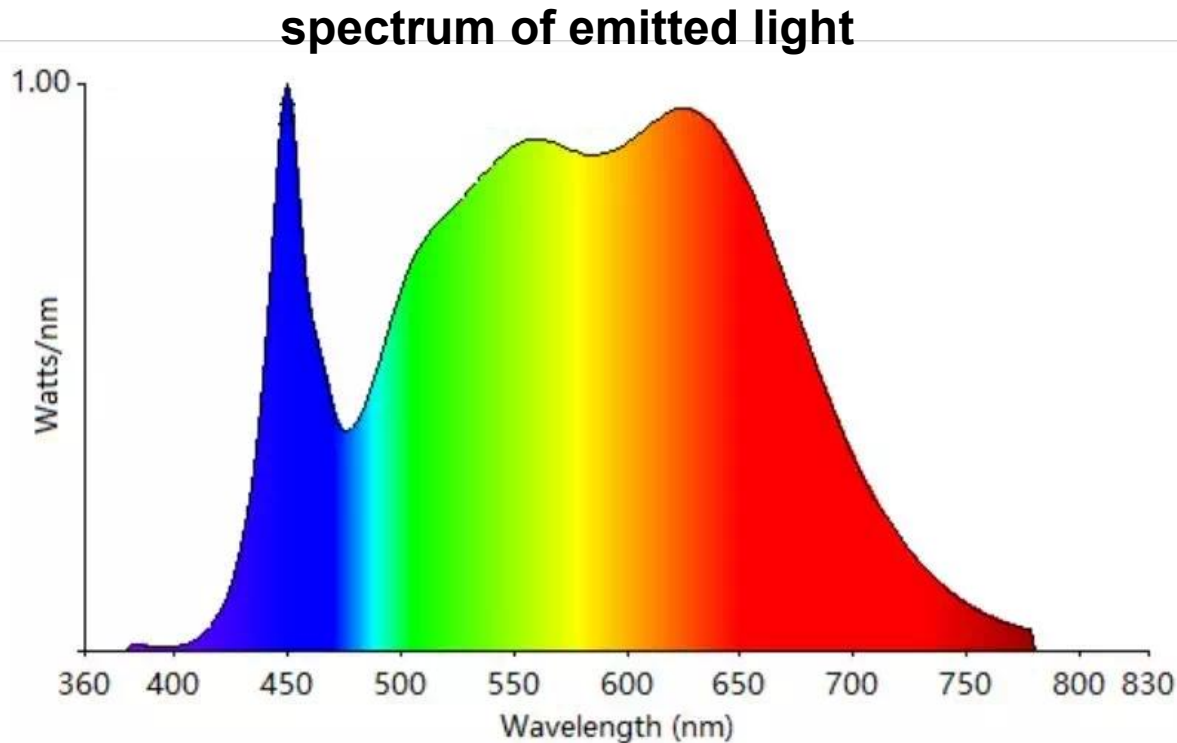

*Repetition from the begin of this lecture:*

A typical human eye will respond to wavelengths from about 400 to 780 nm.

# comment – meaning of spectrum (Fourier spectrum)

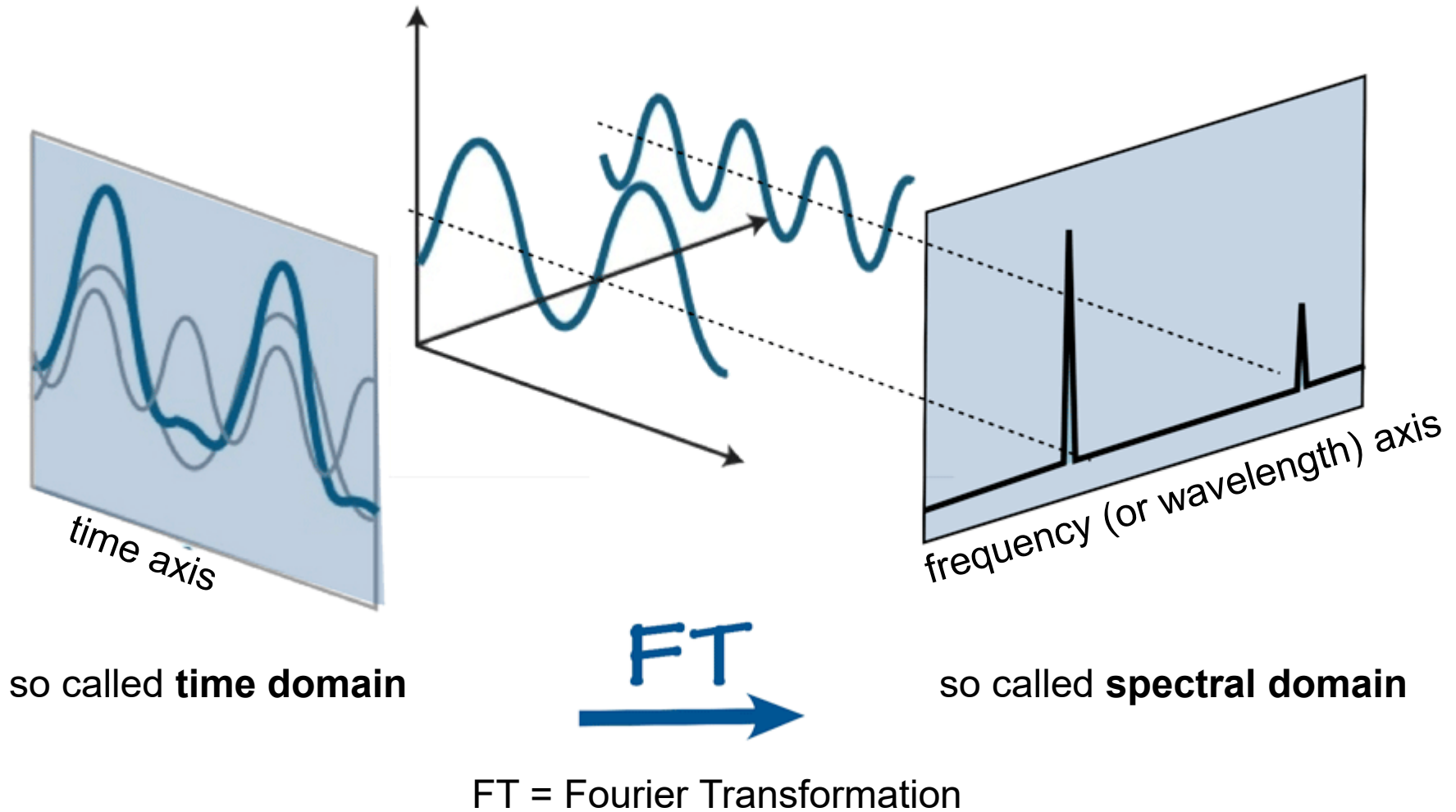

# Halogen lamp

Electrical current heats a so called tungsten (wolfram) filament (cathode) to incandescence (glowing or flaming). Filament is enclosed in an environment of an inert gas (halogene, often bromine or iodine).

Produces light with higher power efficiency than traditional light bulbs

The first halogen lamp was built by **E. G. Fridrich** and **E. H. Wiley** in 1958 .

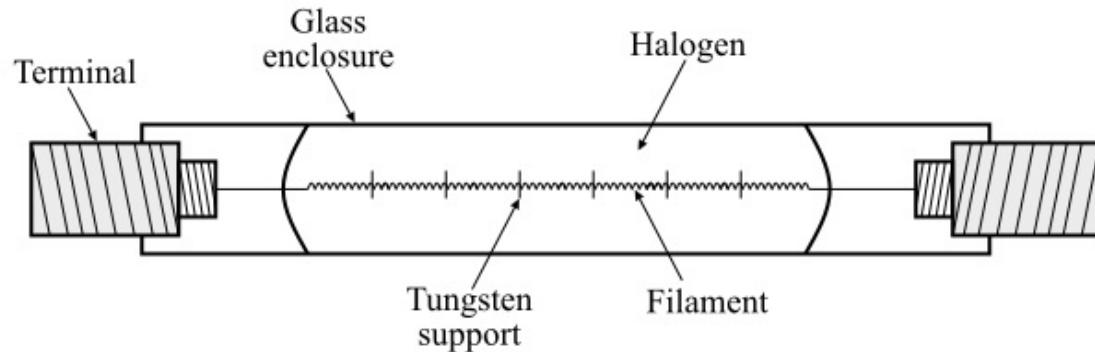
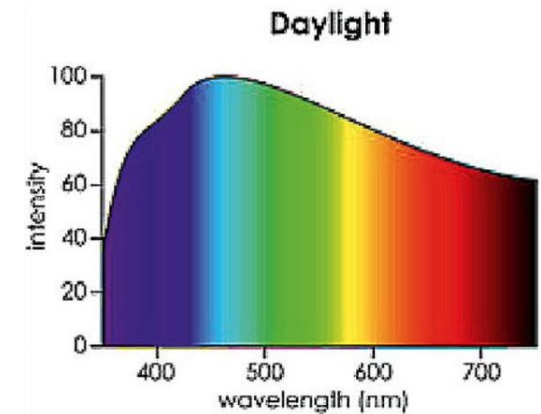
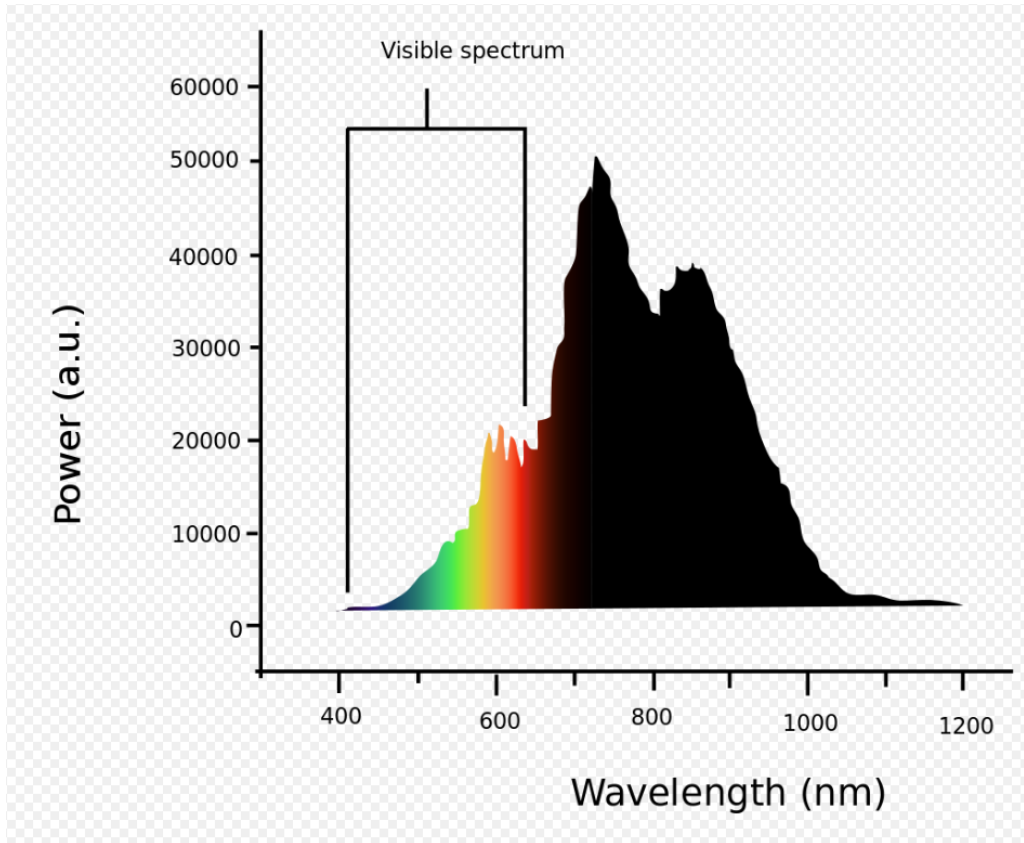

Figure - Halogen Lamp



# Halogen lamp

The spectrum of the tungsten halogen lamp spreads across 350-1200 nm; the emissions in the wavelength region 350-450 nm and 1000-1200 nm are weak and are intense in the wavelength range 600-800 nm.



*Repetition from the begin of this lecture:*

A typical human eye will respond to wavelengths from about 400 to 780 nm.

# LED

LED = **light-emitting diode** is a semiconductor device that emits light when current flows through it. Electrons in the semiconductor recombine with electron holes, releasing energy in the form of photons. The colour of the light (corresponding to the energy of the photons) is determined by the energy required for electrons to cross the band gap of the semiconductor.

The first LED was built in 1962 by **Nick Holonyak Jr.** , an General Electric scientist.



Light from LED is in principle monochromatic (has one wavelength/frequency).

# LED

The spectrum of the LED spreads across 400-730 nm;  
- it produces the full range of the colour spectrum, carrying both visible and invisible colour wavelengths of light.

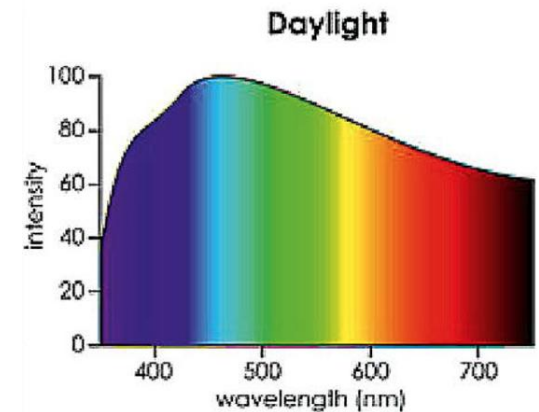
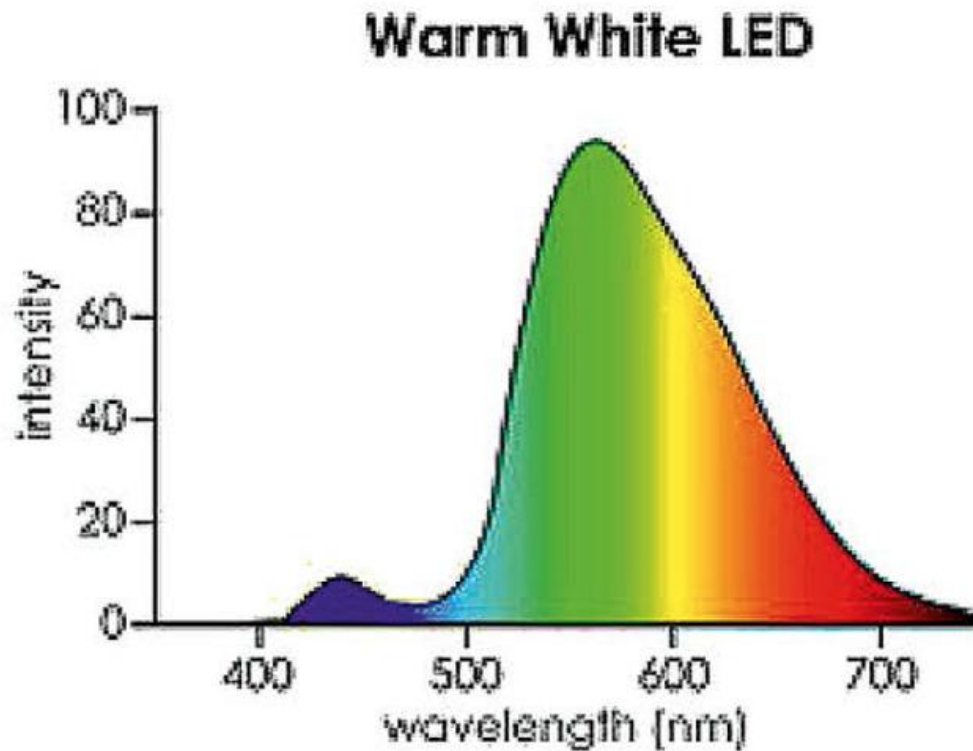

*Repetition from the begin of this lecture:*

A typical human eye will respond to wavelengths from about 400 to 780 nm.

## gas filled tube

Gas-filled tubes exploit phenomena related to electric discharge in gases, and operate by ionizing the gas with an applied voltage sufficient to cause electrical conduction. Used gases: Hydrogen, Deuterium, noble gases...

The first gas discharge tube (so called Geissler tube) was invented by the German glassblower and physicist, **Johann Heinrich Wilhelm Geissler** in 1857.

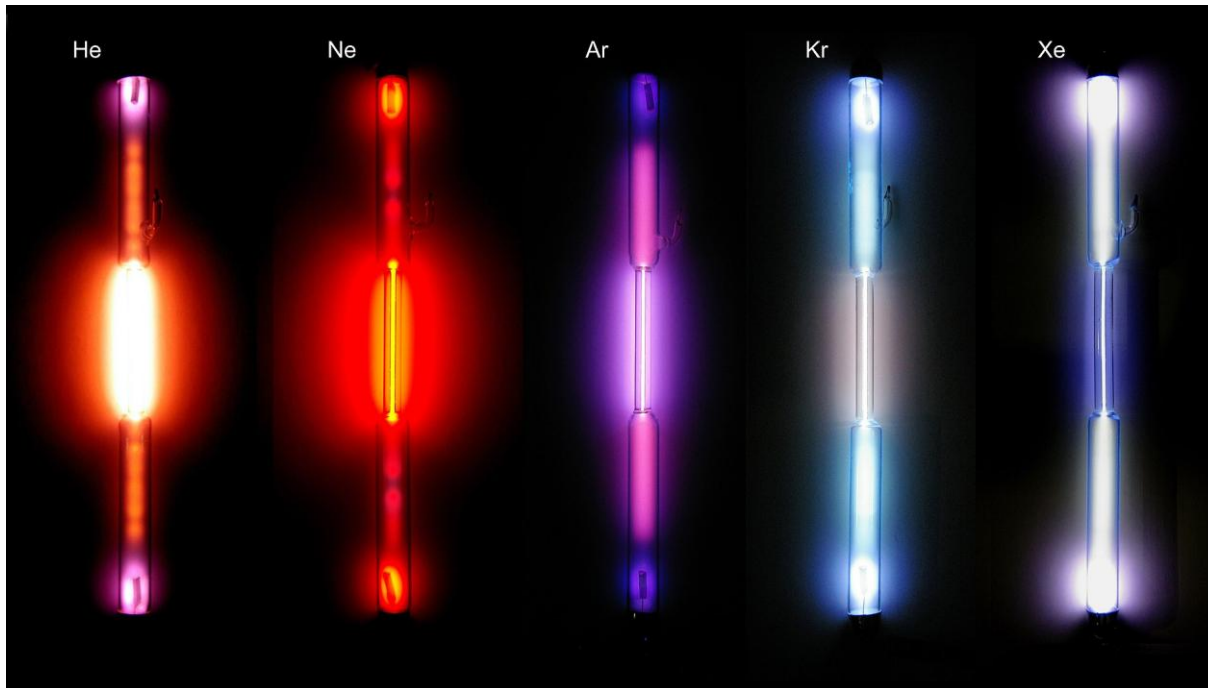

# Absorption spectrum

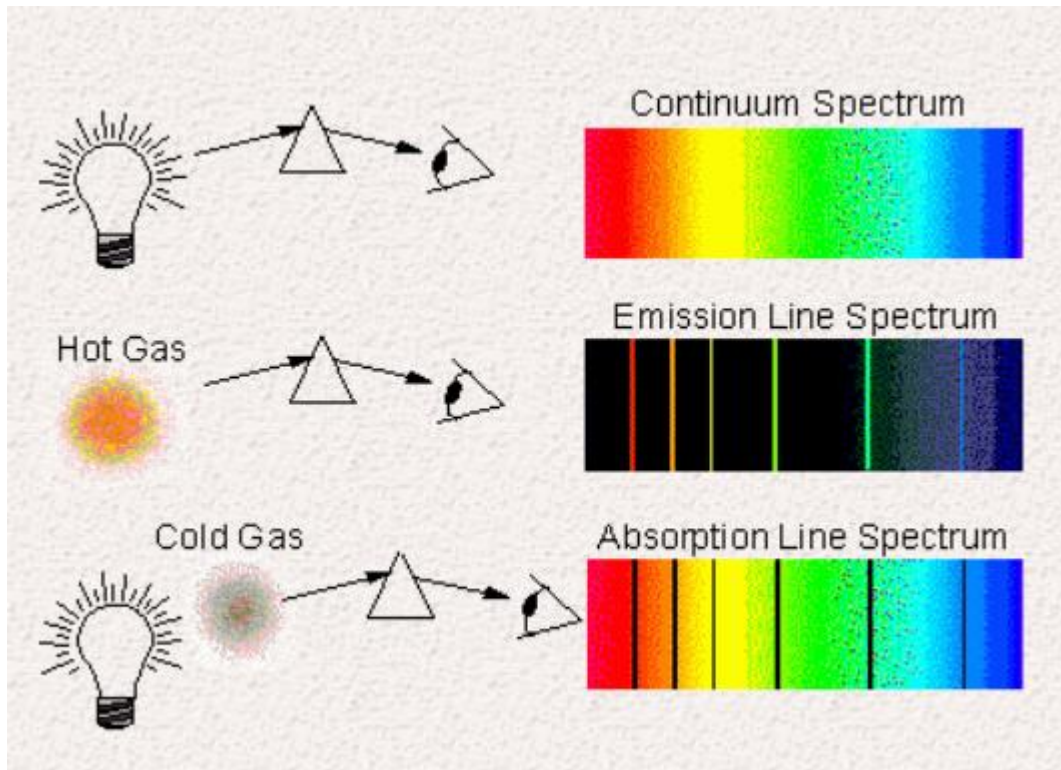
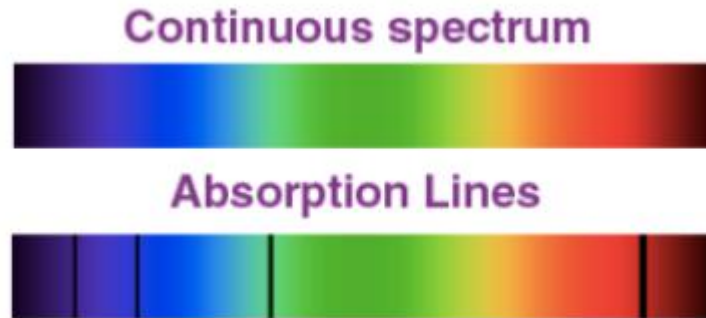

This type of spectrum is produced from some sources of light (e.g. classical light bulb, some LEDs).

This type of spectrum is produced when atoms absorb energy (electrons absorb energy in the ground state to reach higher energy states).

# Absorption spectrum

Spectrum of the light from Sun is not a continuous spectrum; however, it still represents visible radiation.

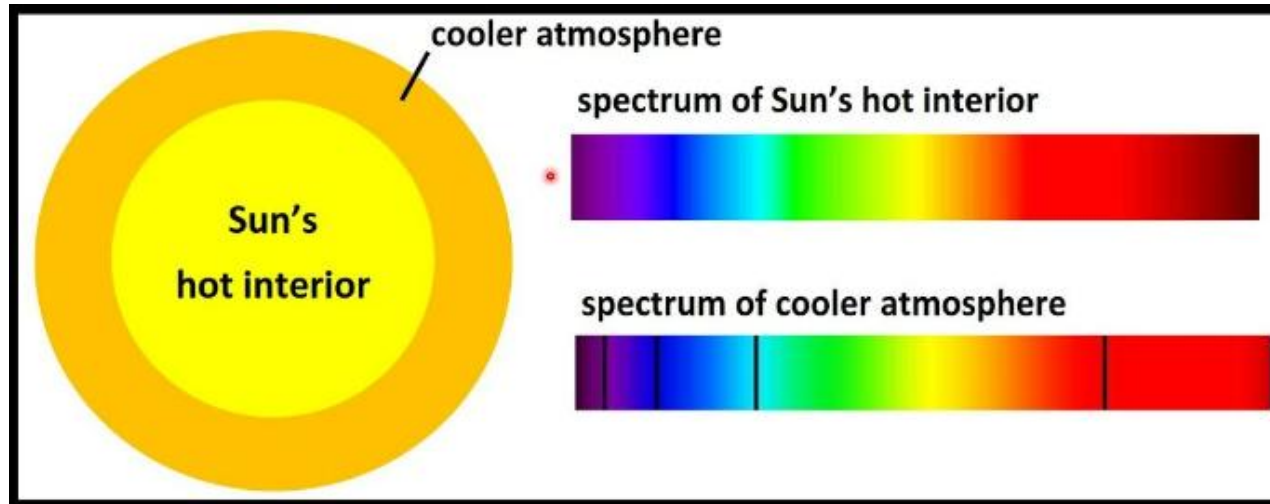

Hydrogen Emission spectrum

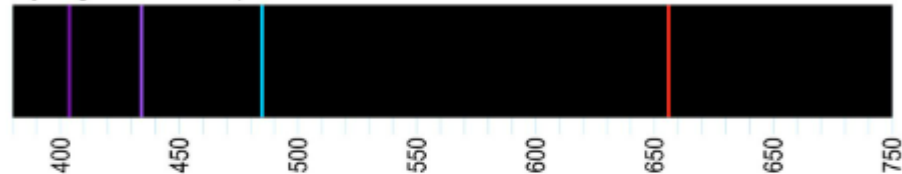

Hydrogen Absorption spectrum

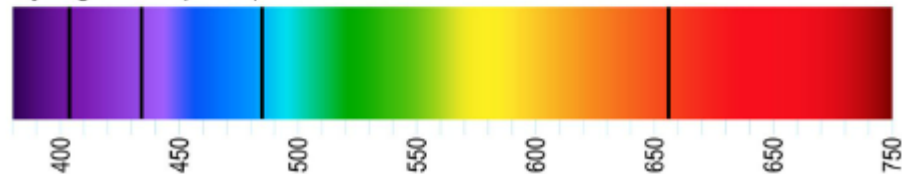

# Topic 10: light, optics

## Content:

- introduction to optics
- reflection VS refraction
- geometrical optics, lenses, mirrors
- microscope
- electron microscope, laser
- black body radiation
- units: lumen, lux, candela

# reflection vs refraction

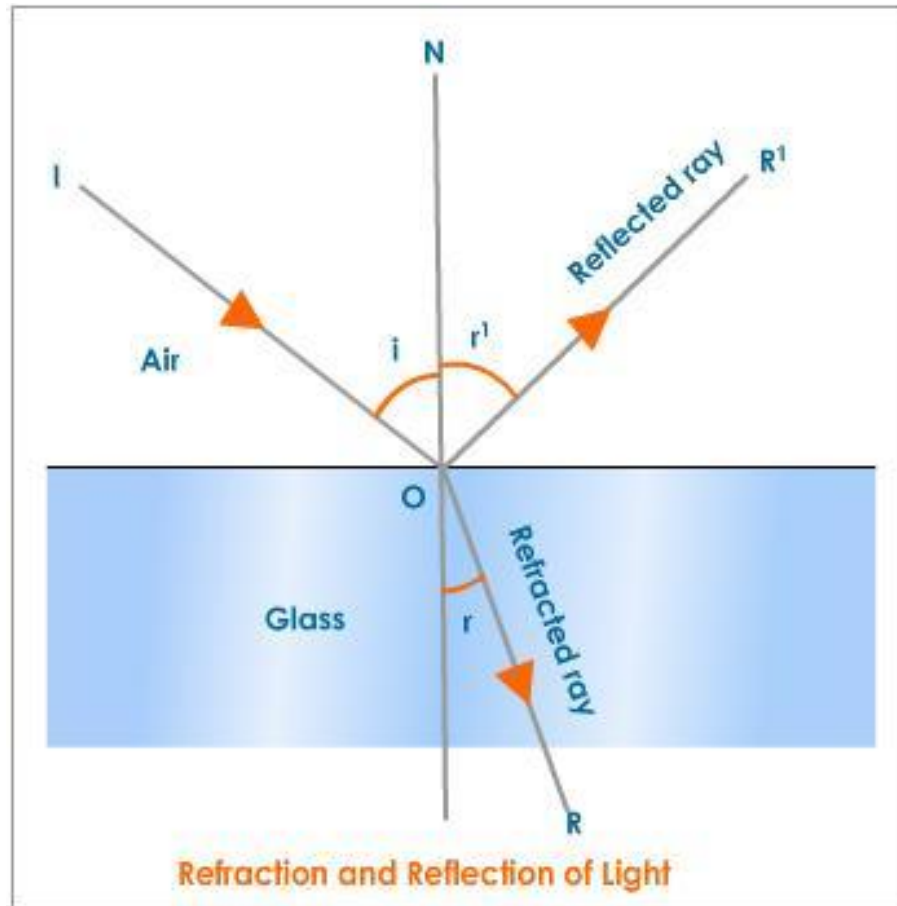

**Reflection** is the change in direction of a wavefront at an interface between two different media so that the wavefront returns into the medium from which it originated.

**Refraction** is the change in direction of propagation of a wave due to a change in its transmission medium.

two important laws

- 1) law of reflection
- 2) law of refraction

# law of reflection

The **law of reflection** states that  $\theta_i = \theta_r$ , or in other words, the angle of incidence equals the angle of reflection.

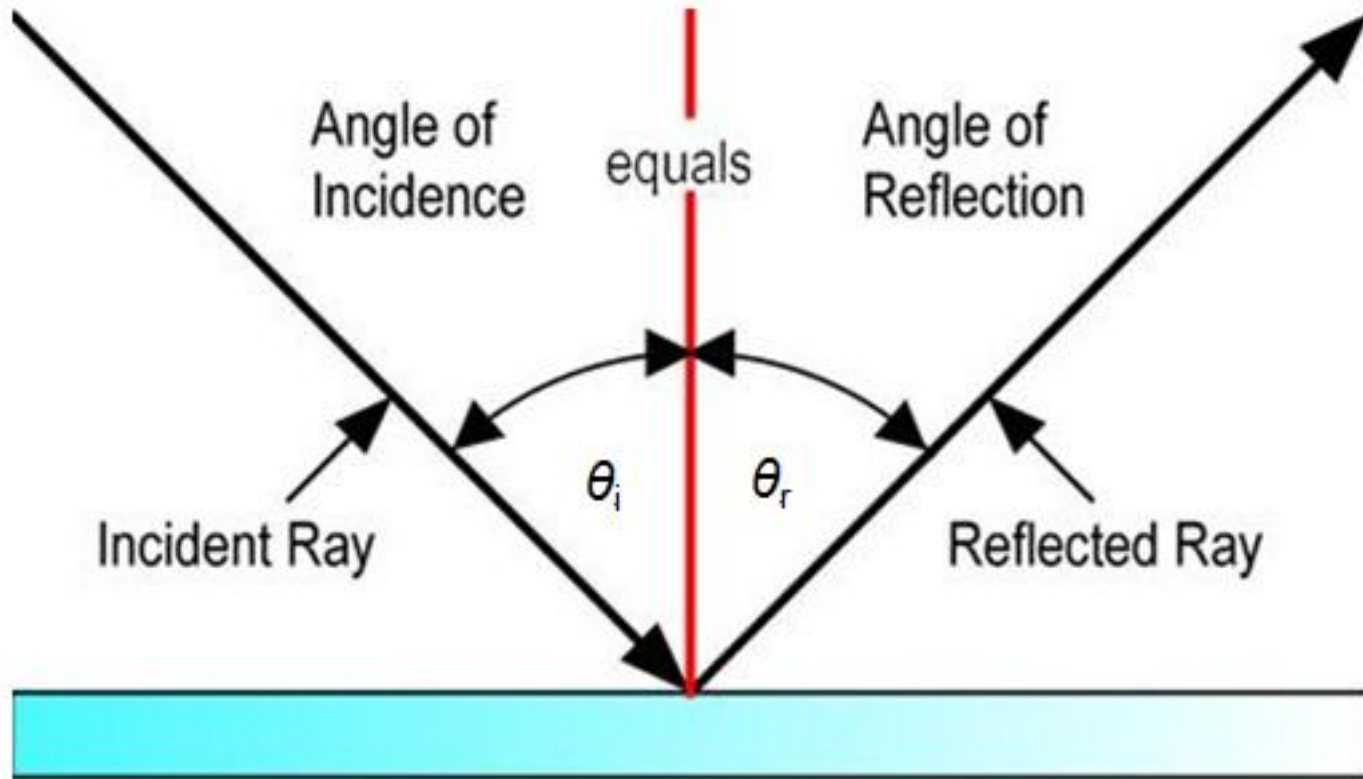

# law of refraction (Snell's law)

Snell's law states that the ratio of the sines of the **angle of incidence**  $\theta_1$  and **angle of refraction**  $\theta_2$  is equivalent to the ratio of velocities ( $v_1/v_2$ ) in the two media, or equivalently, to the opposite ratio of the **indices of refraction** ( $n_2/n_1$ ):

$$\frac{\sin \theta_1}{\sin \theta_2} = \frac{v_1}{v_2} = \frac{n_2}{n_1}$$

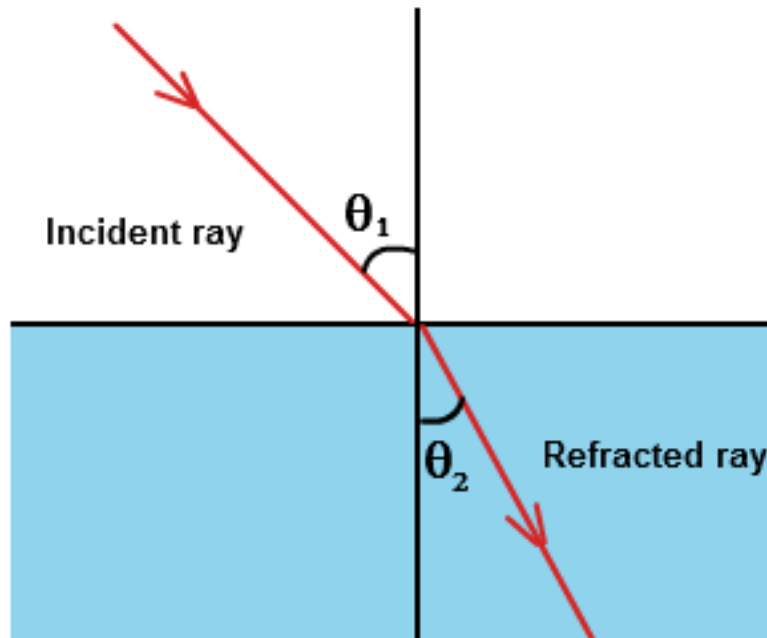

## Index of refraction $n$

(or refractive index)

of a material is a dimensionless number that describes how light propagates through that medium. It is defined as the ratio:

$$n = \frac{c}{v}$$

here:  $c$  is the speed of light in vacuum and  $v$  is the speed of light in the medium, it is always greater than 1 (it cannot be less than 1).

# law of refraction (Snell's law)

Snell's law states that the ratio of the sines of the **angle of incidence**  $\theta_1$  and **angle of refraction**  $\theta_2$  is equivalent to the ratio of velocities ( $v_1/v_2$ ) in the two media, or equivalently, to the opposite ratio of the **indices of refraction** ( $n_2/n_1$ ):

$$\frac{\sin \theta_1}{\sin \theta_2} = \frac{v_1}{v_2} = \frac{n_2}{n_1}$$

**Index of refraction  $n$**   
(or refractive index)

## Derivation:

Snell's law can be derived from Fermat's principle, which states that the light travels the path which takes the least time.

By taking the derivative of the optical path length, the stationary point is found giving the path taken by the light.



## Derivation of Snell's Law

YouTube · Matthew Johnson

19. 4. 2022

<https://www.youtube.com/watch?v=39W2MGXDPQc>

# law of refraction (Snell's law)

Snell's law states that the ratio of the sines of the **angle of incidence**  $\theta_1$  and **angle of refraction**  $\theta_2$  is equivalent to the ratio of velocities ( $v_1/v_2$ ) in the two media, or equivalently, to the opposite ratio of the **indices of refraction** ( $n_2/n_1$ ):

$$\frac{\sin \theta_1}{\sin \theta_2} = \frac{v_1}{v_2} = \frac{n_2}{n_1}$$

**Index of refraction  $n$**   
(or refractive index)

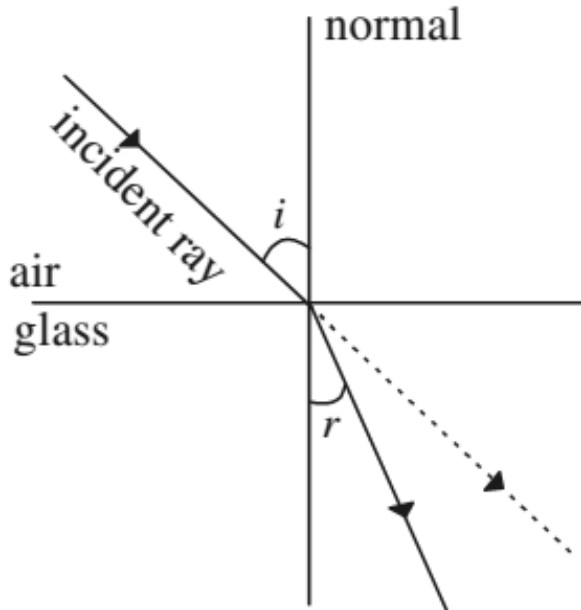

refraction towards the normal line  
(denser material in bottom)

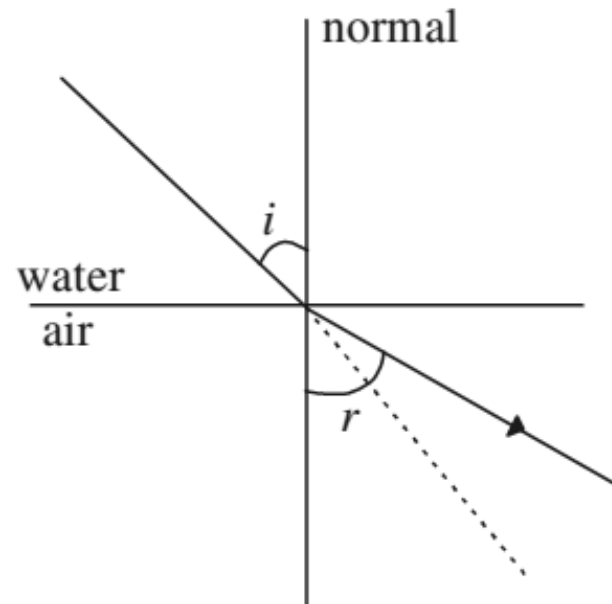

refraction away from the normal line  
(sparse material in bottom)

# refraction

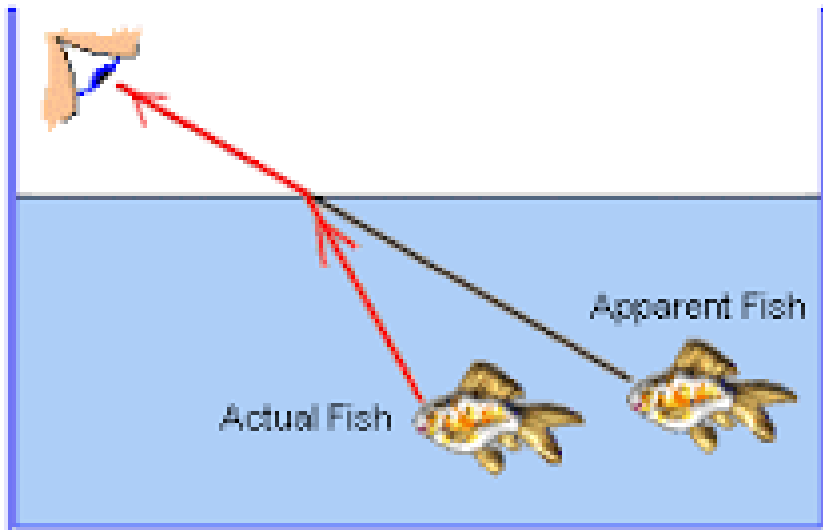
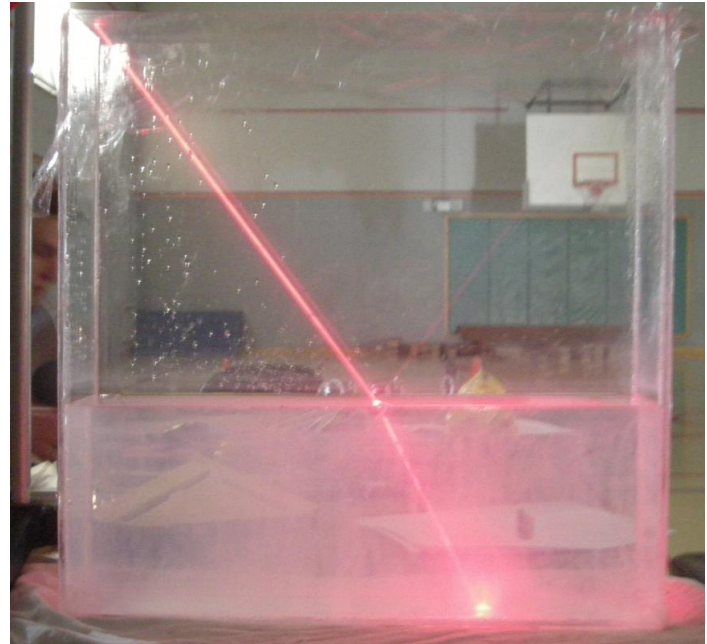
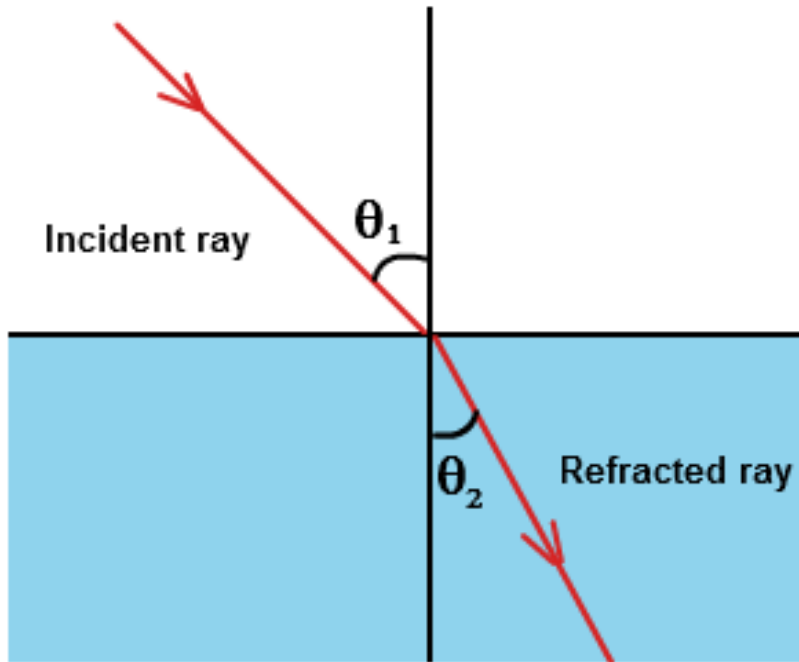

# refraction

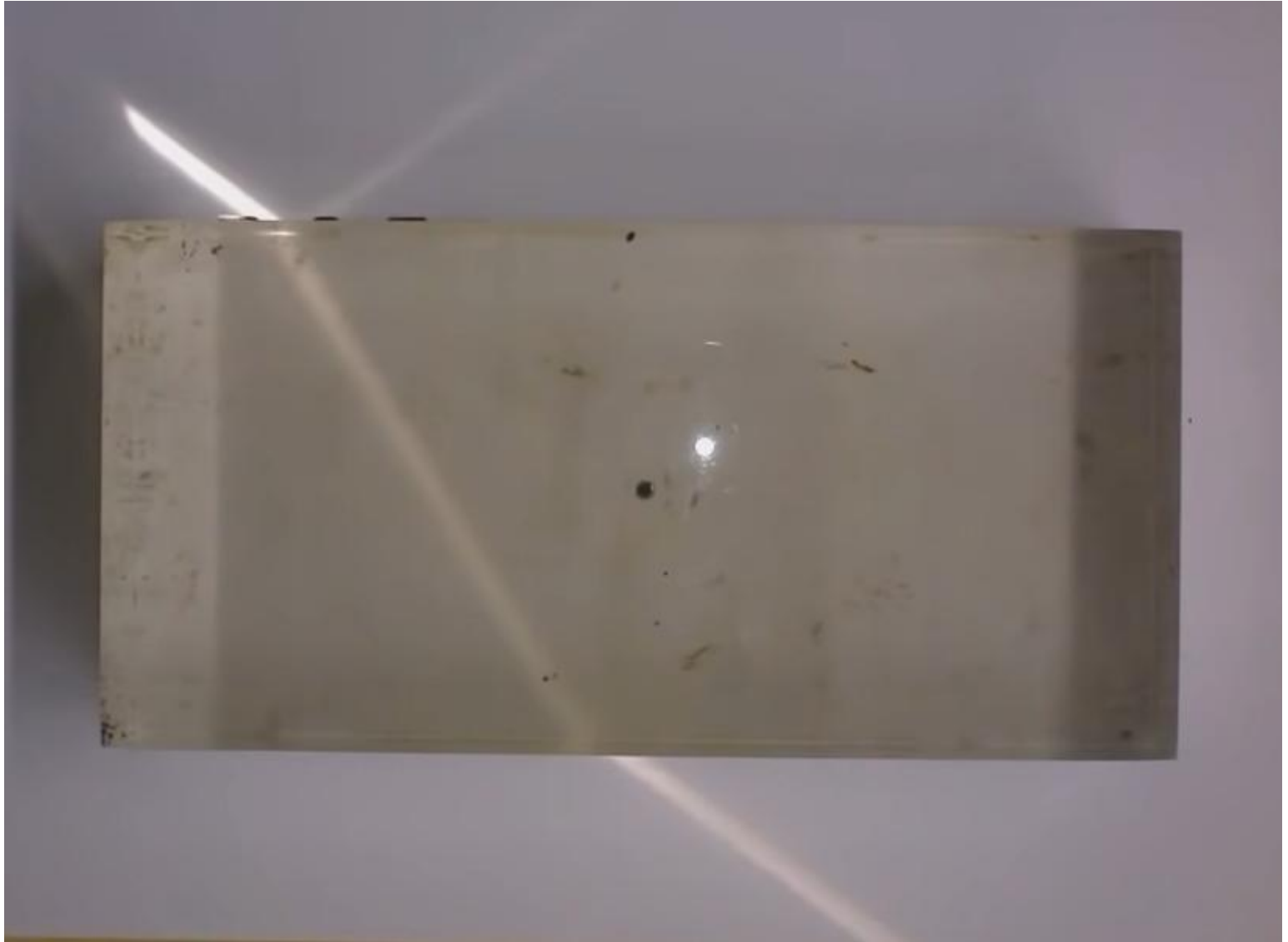

very good experiments:

<https://www.youtube.com/watch?v=uQE659ICjqQ>

# law of refraction (Snell's law)

Index of refraction  $n$  for various materials  
(for an average value of  $\lambda=589$  nm):

Media	Index of Refraction
Vacuum	1.00
Air	1.0003
Carbon dioxide gas	1.0005
Ice	1.31
Pure water	1.33
Ethyl alcohol	1.36
Quartz	1.46
Vegetable oil	1.47
Olive oil	1.48
Acrylic	1.49
Table salt	1.50
Glass	1.51
Sapphire	1.77
Zircon	1.92
Cubic zirconia	2.16
Diamond	2.42
Gallium phosphide	3.50

# law of refraction (Snell's law)

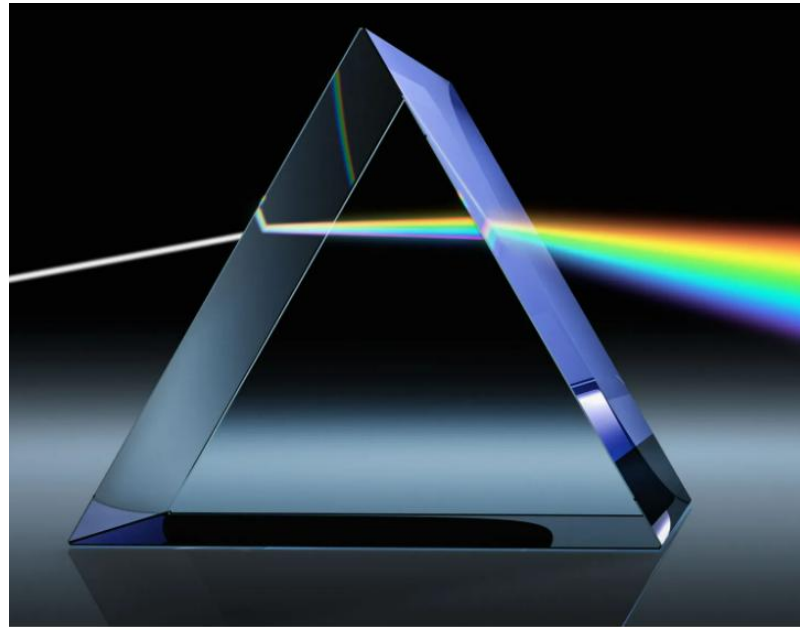

White light entering a prism is bent, or refracted, and the light separates into its constituent wavelengths.

Each wavelength of light has a different colour and bends (refracts) at a different angle – because the index of refraction is a linear function of the wavelength.

Reason: Different wavelengths interfere to different extents with the atoms of the medium.

# law of refraction (Snell's law)

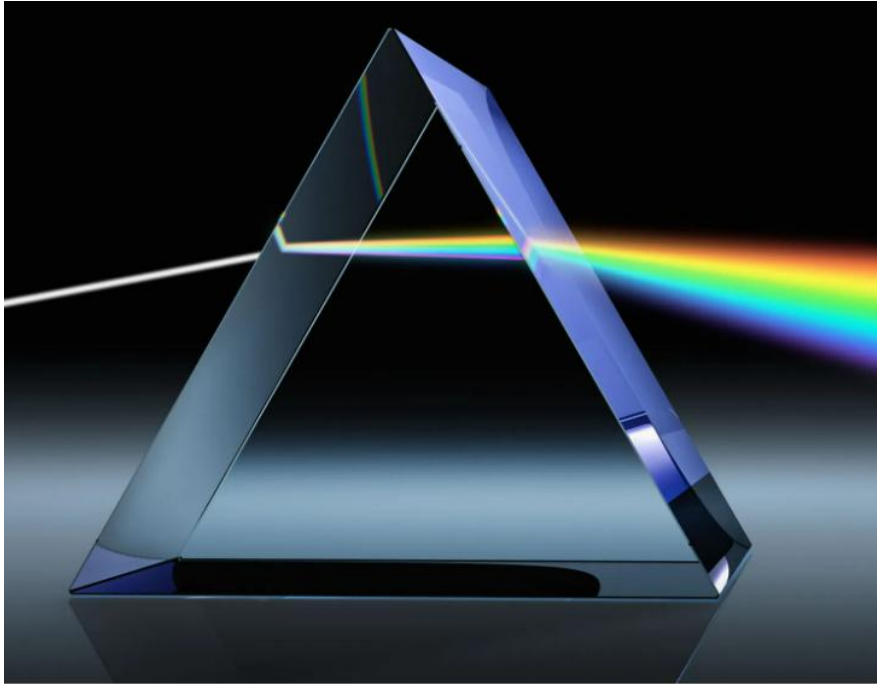

Table: index of refraction for borosilicate glass

colour	wavelength [nm]	refract. index
red	640	1.50917
yellow	589	1.51124
green	509	1.51534
blue	486	1.51690
violet	434	1.52136

Different wavelengths causes difference in velocity of colours while passing from one medium to another through glass prism, because every colour has different wavelength.

Refractive index depends on wavelength of light, so different wavelength mean different refractive index which means different velocities.

# law of refraction (Snell's law)

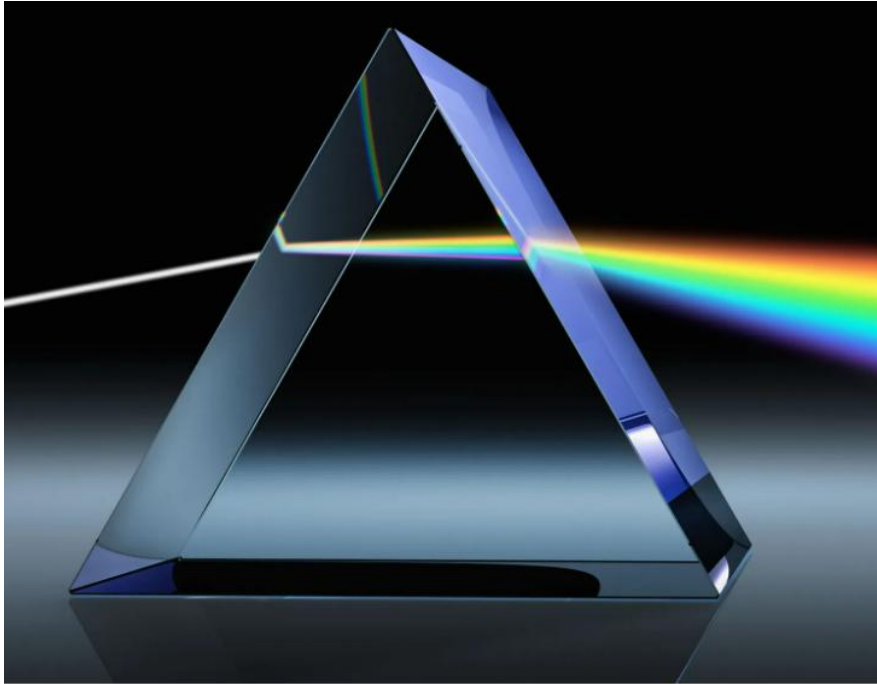

Second important phenomenon:  
Combination of refraction toward the normal  
(entering the glass) with the refraction away  
from the normal (leaving the glass).

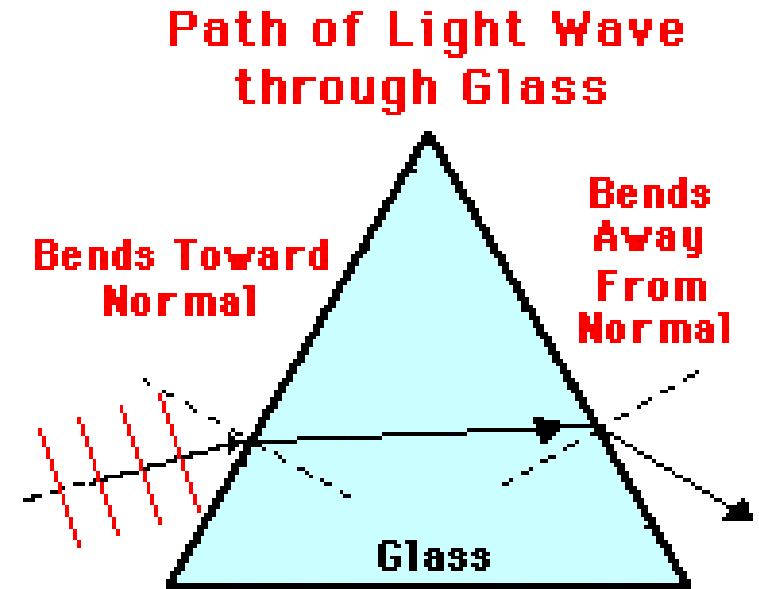

# Lecture 10: light, optics

## Content:

- introduction to optics
- reflection VS refraction
- geometrical optics, lenses, mirrors
- microscope
- electron microscope, laser
- black body radiation
- units: lumen, lux, candela

# foundations of geometrical optics - lenses

A **lens** is a transmissive optical device that affects the focus of a light beam through refraction.

A **lens can focus light** to form an image, unlike a prism, which refracts light without focusing.

Devices that similarly refract radiation **other than visible light** are also called lenses, such as microwave lenses or acoustic lenses.

---

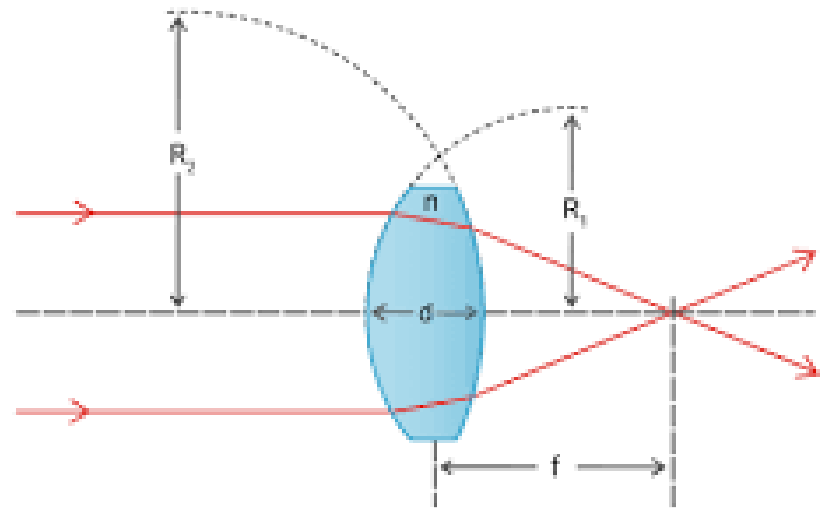

$R_1, R_2$  – curvature radii,  
 $d$  – thickness of the lens,  
 $f$  – focal length

## foundations of geometrical optics - lenses

A **lens** is a transmissive optical device that affects the focus of a light beam through refraction.

A **lens can focus light** to form an image, unlike a prism, which refracts light without focusing.

Devices that similarly refract radiation other than visible light are also called lenses, such as microwave lenses or acoustic lenses.

---

Lenses are **classified by the curvature of the two optical surfaces**:

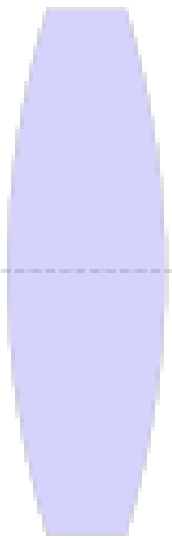

Biconvex

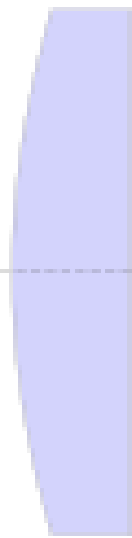

Plano-convex

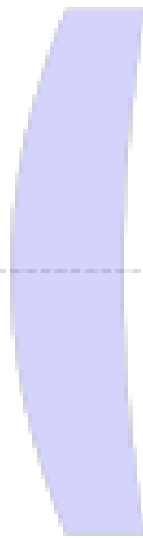

Positive meniscus



Negative meniscus



Plano-concave

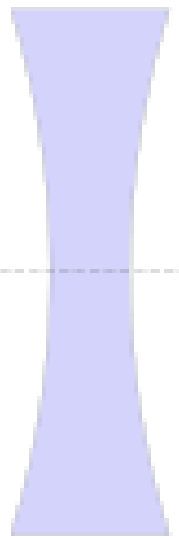

Biconcave

# foundations of geometrical optics - lenses

Most important are **biconvex** (positive, converging) and **biconcave** (negative, diverging) lenses.

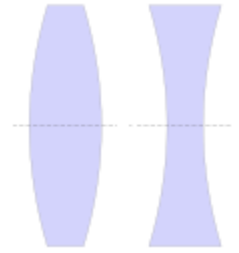

If the lens is **biconvex** or **plano-convex**, a collimated beam of light converges to a spot (a **focus** or **focal point**) behind the lens. The distance from the lens to the spot is the **focal length** of the lens (commonly abbreviated  $f$  in diagrams and equations).

Displayed image is reduced for distance smaller than  $f$  and reversed for distance larger than  $f$ .

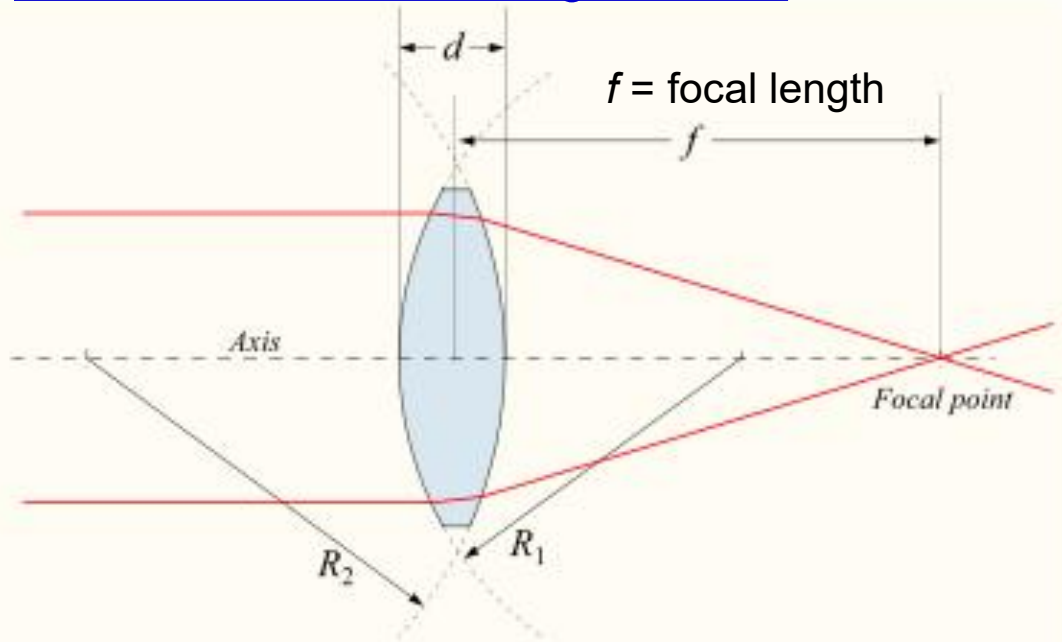

*Positive (converging) lens*

## biconvex

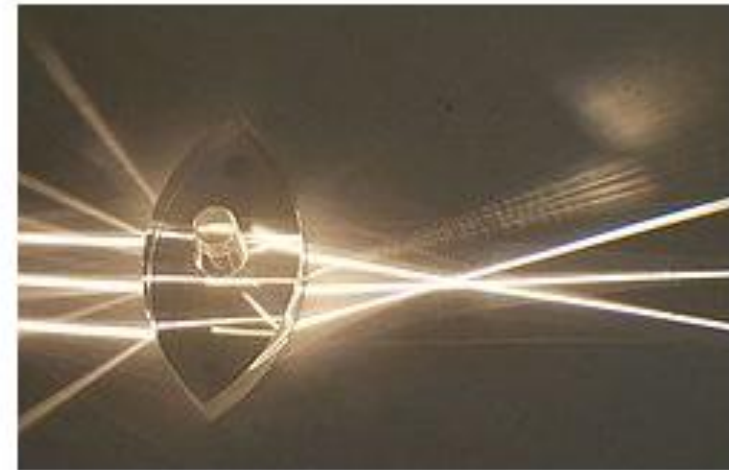

$R_1, R_2$  – curvature radii,  $d$  – thickness of the lens,  $f$  – focal length

# foundations of geometrical optics - lenses

Most important are **biconvex** (positive, converging) and **biconcave** (negative, diverging) lenses.

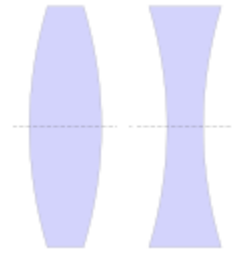

If the lens is **biconcave** or **plano-concave**, a collimated beam of light passing through the lens is diverged (spread). The beam, after passing through the lens, appears to emanate from a particular point on the axis in front of the lens. The distance from this point to the lens is also known as the **focal length**, though it is negative with respect to the focal length of a converging lens.

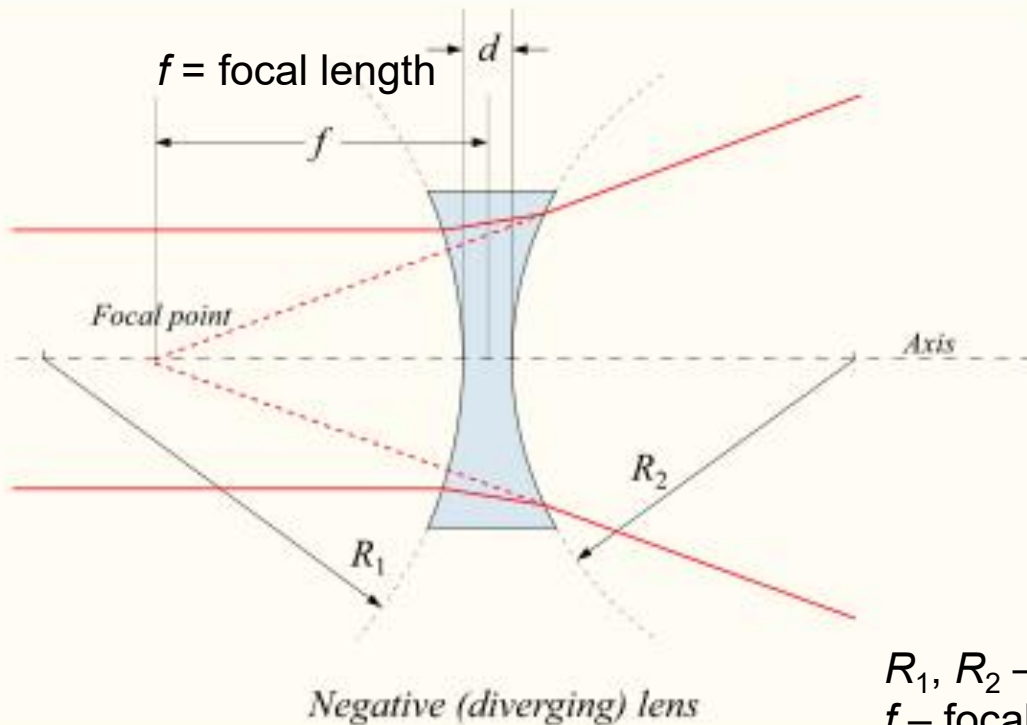

## biconcave

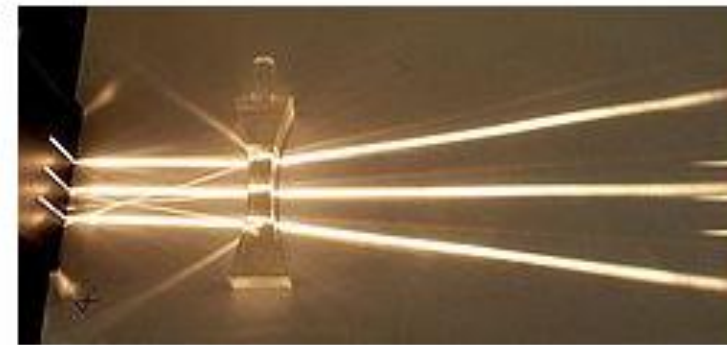

$R_1, R_2$  – curvature radii,  $d$  – thickness of the lens,  $f$  – focal length

# foundations of geometrical optics - lenses

**Thin lens formula:** ( $d$  is small compared to  $R_1$  and  $R_2$ )

$R_1, R_2$  – curvature radii,  $d$  – thickness of the lens

If the distances from the object to the lens and from the lens to the image are  $S_1$  and  $S_2$  respectively, for a lens of negligible thickness, in air, the distances are related by the thin lens formula ( $f$  – focal length):

$$\frac{1}{S_1} + \frac{1}{S_2} = \frac{1}{f}$$

$$\frac{1}{\text{object distance}} + \frac{1}{\text{image distance}} = \frac{1}{\text{focal length}}$$

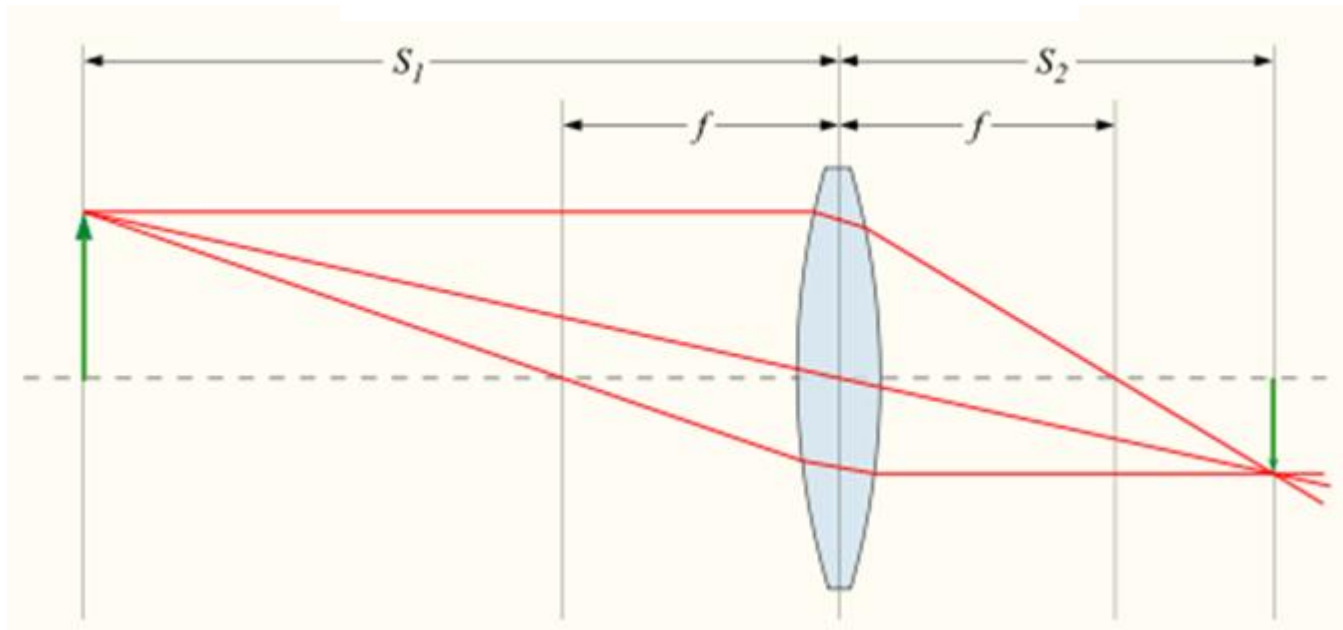

derivation of thin lense formula:

<https://www.youtube.com/watch?v=x9F0AQCGkbc>

# Thin lens formula derivation (1/2)

$$\frac{1}{S_1} + \frac{1}{S_2} = \frac{1}{f}$$

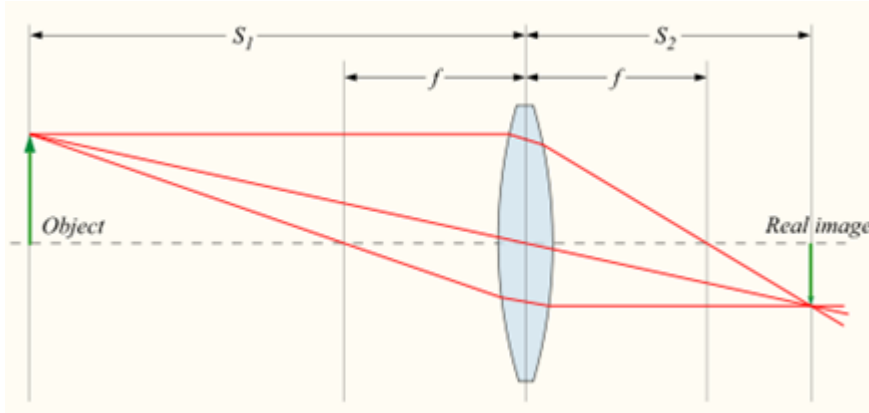

Parameters:

$S_1$  and  $S_2$  are distances,  $f$  – focal length,  $h_o$  – object height,  $h_i$  – image height, unknown are:  $h_i$  and  $S_2$

Derivation works with the *similarity of triangles* (ratios of their sides, SSS), using 2 pairs of triangles:

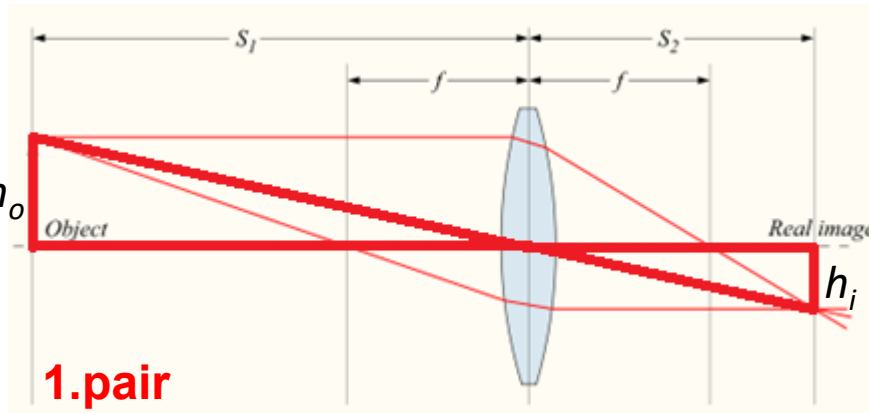

$$\frac{h_i}{h_o} = \frac{S_2}{S_1}$$

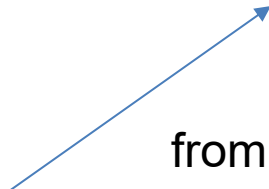
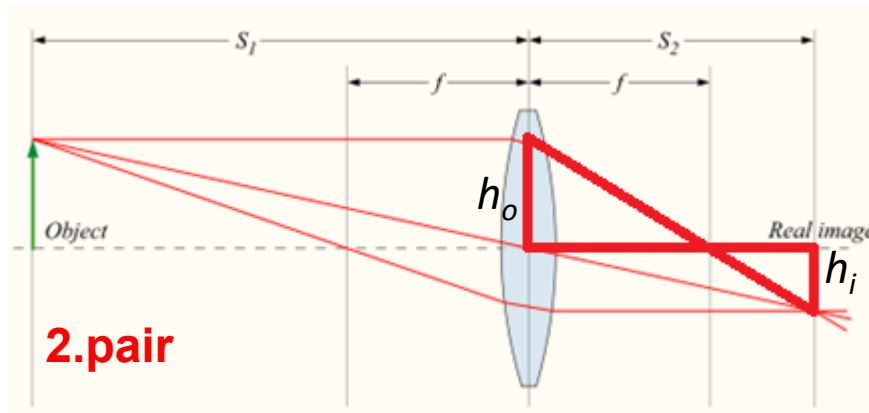

$$\frac{h_i}{h_o} = \frac{S_2 - f}{f}$$

from  $h_i/h_o = h_i/h_o$  it follows:

$$\frac{S_2}{S_1} = \frac{S_2 - f}{f}$$

# Thin lens formula derivation (2/2)

$$\frac{1}{S_1} + \frac{1}{S_2} = \frac{1}{f}$$

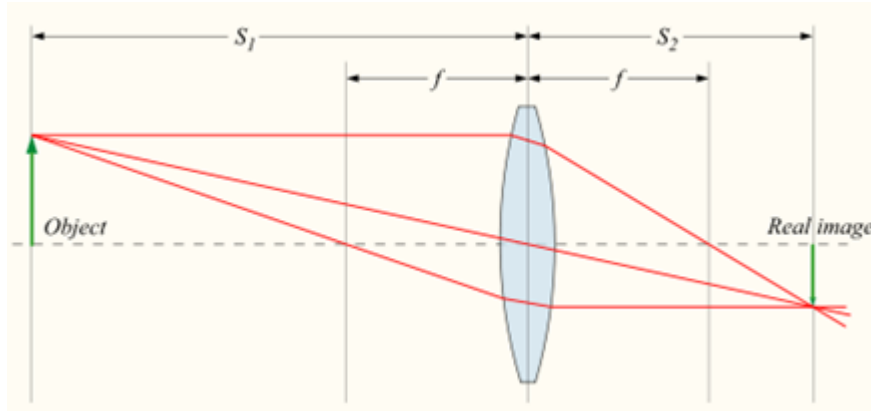

Parameters:

$S_1$  and  $S_2$  are distances,  $f$  – focal length,  $h_o$  – object height,  $h_i$  – image height, unknown are:  $h_i$  and  $S_2$

Continuation from previous slide - from  $h_i/h_o = h_i/h_o$  it follows:

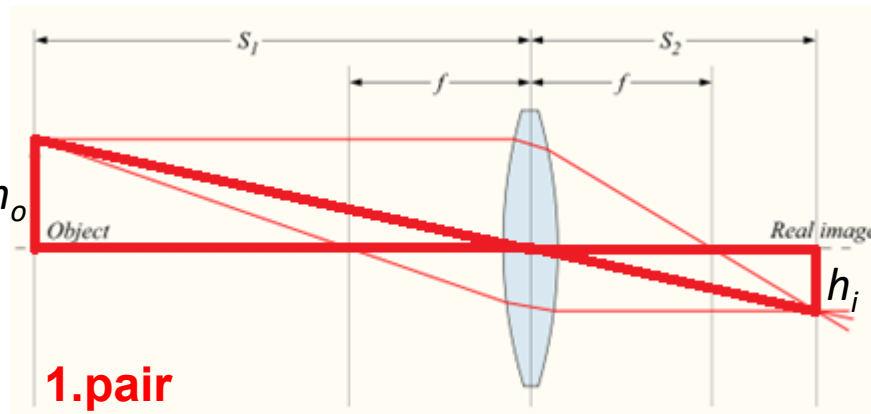

$$\frac{S_2}{S_1} = \frac{S_2 - f}{f} \quad / \cdot f \quad / \cdot S_1$$

$$S_2 f = S_1 (S_2 - f)$$

$$S_2 f + S_1 f = S_1 S_2 \quad / (1/f)$$

$$S_2 + S_1 = \frac{S_1 S_2}{f} \quad / (1/S_1 S_2)$$

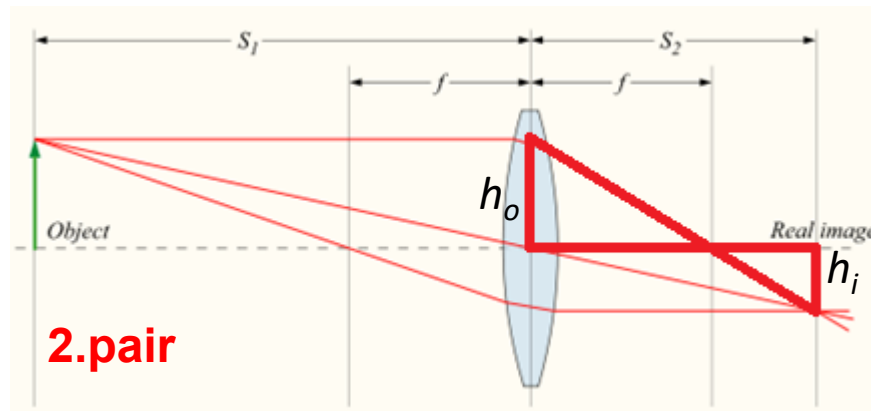

$$\frac{1}{S_1} + \frac{1}{S_2} = \frac{1}{f}$$

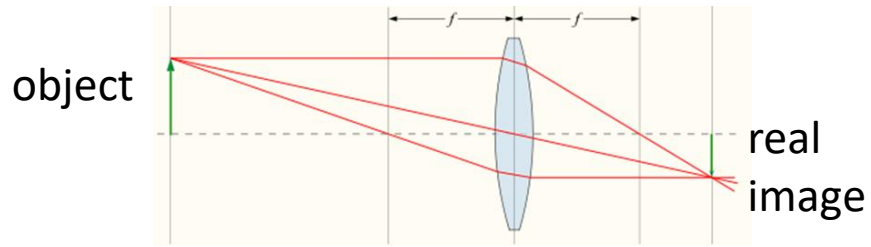

principle  
of a camera  
(human eye)

# foundations of geometrical optics - lenses

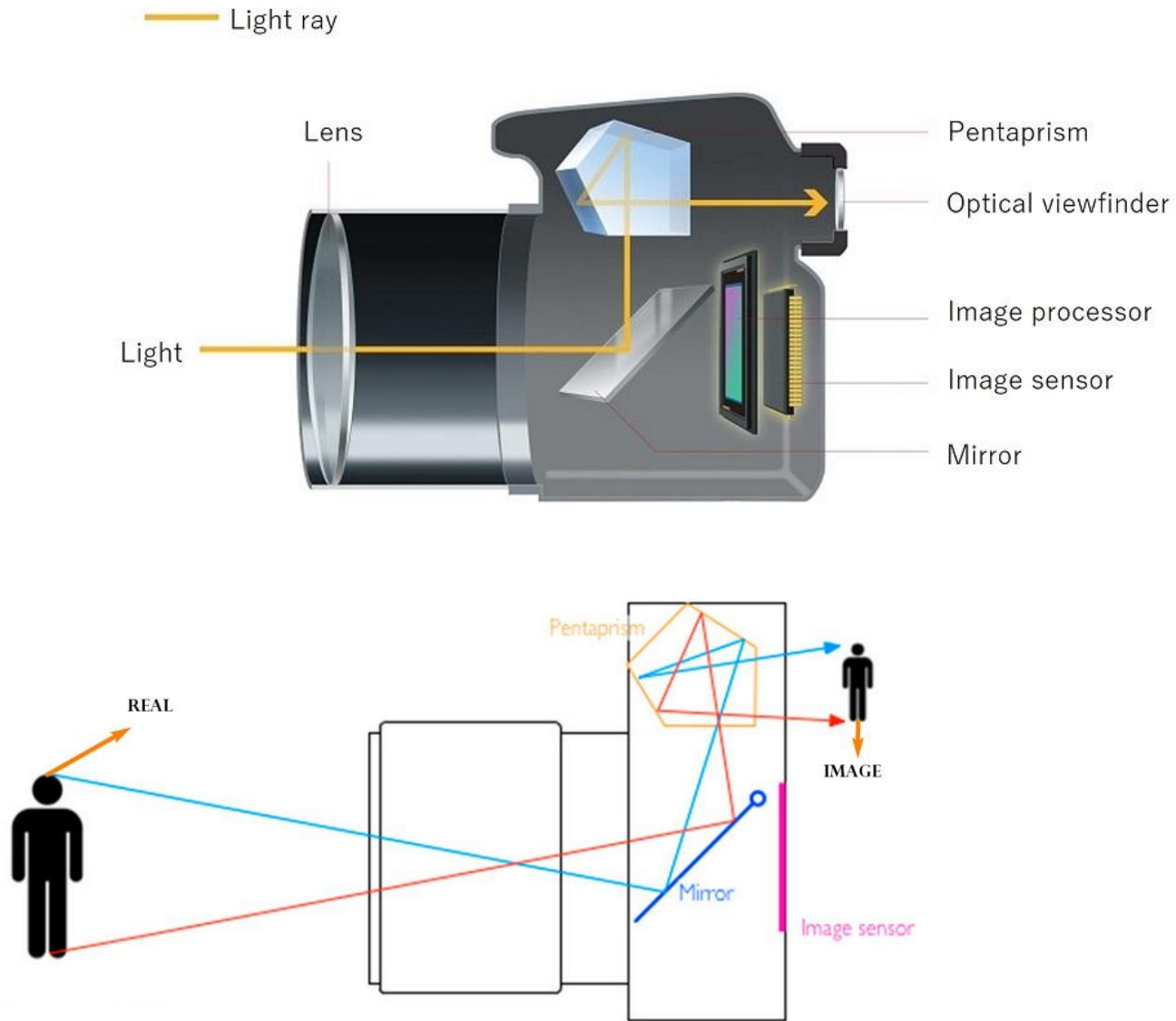

This is the principle of the camera, and of the human eye.

# foundations of geometrical optics - lenses

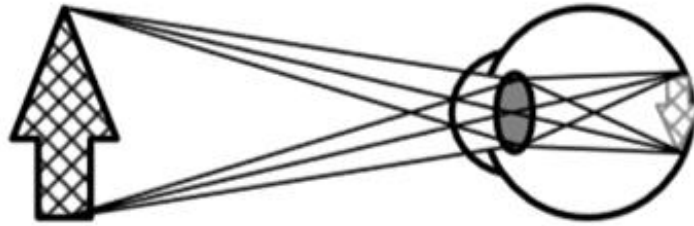

**FIGURE 6:1** A *real, inverted* image of an object is formed upon the retina at the back of the eye.

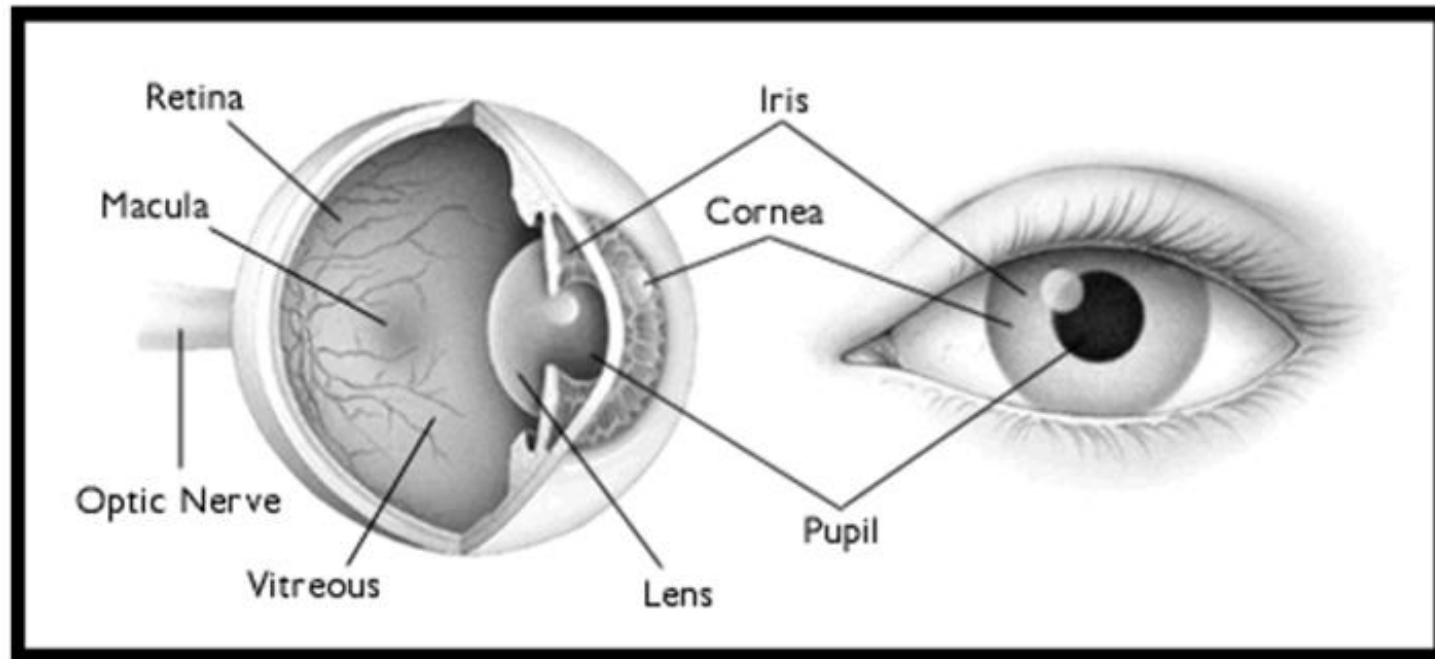

**FIGURE 6:2** Basic anatomical and optical structures of the eye, including the cornea, pupil, crystalline lens, and retina. In addition, the *macula*—which is the most sensitive area of the retina—and the *optic nerve* are shown.

This is the principle of the camera, and of the human eye.

# foundations of geometrical optics - lenses

## Correction lenses (eye-glasses)

hyperopic eye  
(rays of light focus behind the retina)

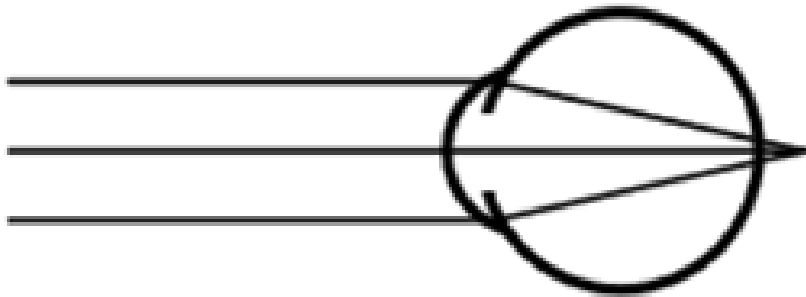

myopic eye  
(rays of light focus before the retina)

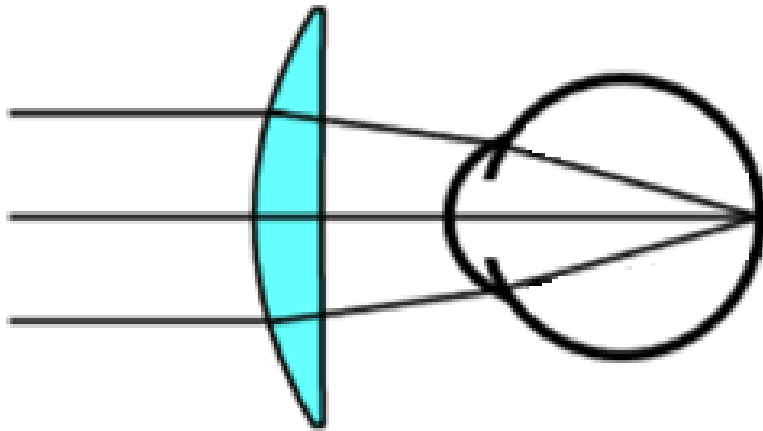
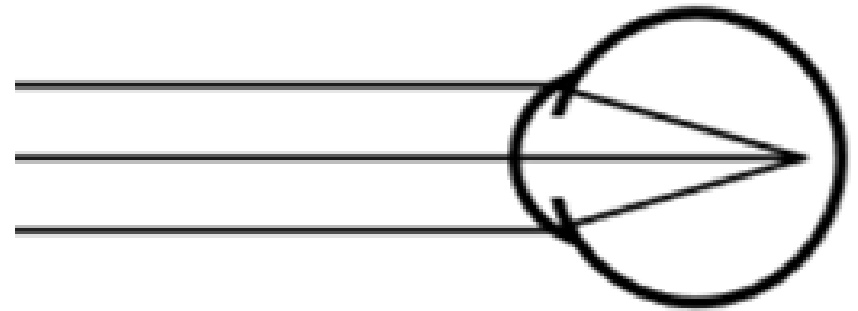

corrective plus lens

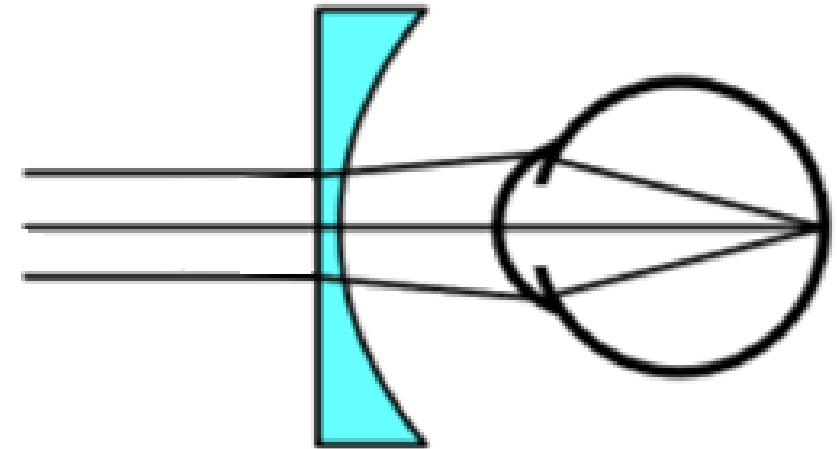

corrective minus lens

Experiment with a glass of water:

<http://www.youtube.com/watch?v=G303o8pJzls>



# foundations of geometrical optics - lenses

**Thin lens formula:** ( $d$  is small compared to  $R_1$  and  $R_2$ )

In some cases (distance  $S_1 < f$ ) resulting  $S_2$  is negative, indicating that the image is formed on the opposite side of the lens from where those rays are being considered. Since the diverging light rays emanating from the lens never come into focus, and those rays are not physically present at the point where they appear to form an image, this is called a **virtual image**.

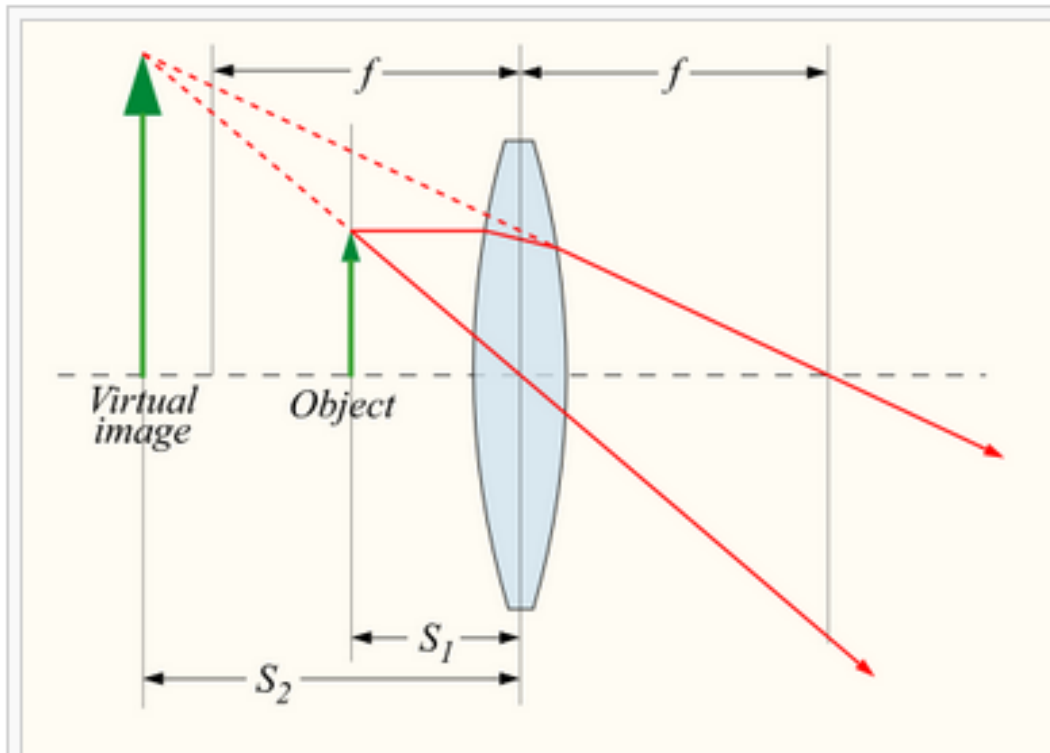

Virtual image formation using a positive lens as a magnifying glass.

We can work with  $S_2$  as a positive number, but the thin lens formula has to be used in changed version:

$$\frac{1}{S_1} - \frac{1}{S_2} = \frac{1}{f}$$

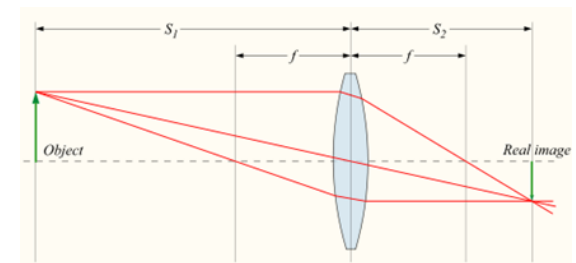

# foundations of geometrical optics - lenses

**Thin lens formula:** ( $d$  is small compared to  $R_1$  and  $R_2$ )

In some cases (distance  $S_1 < f$ ) resulting  $S_2$  is negative, indicating that the image is formed on the opposite side of the lens from where those rays are being considered. Since the diverging light rays emanating from the lens never come into focus, and those rays are not physically present at the point where they appear to form an image, this is called a **virtual image**.

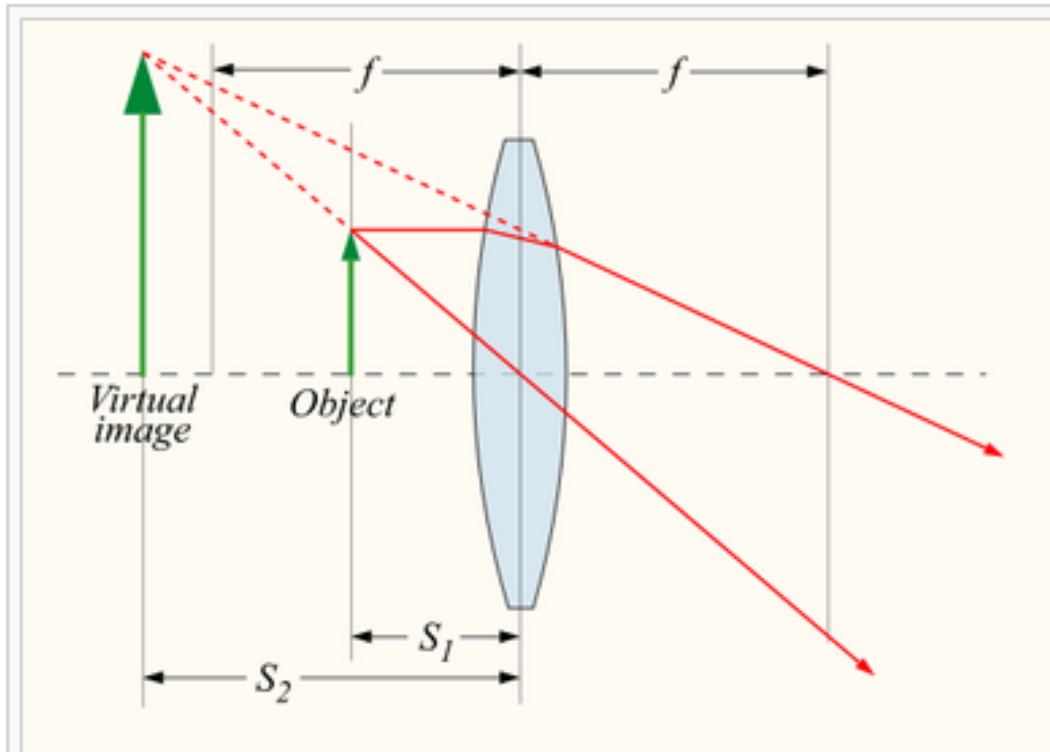

Virtual image formation using a positive lens as a magnifying glass.

In this case we often speak about so called magnifying lenses and the parameter  $h_i/h_o$  is called as magnification ( $m$ ). It can be shown that it is also equal to the ratio  $S_1/S_2$ .

$$m = \frac{h_i}{h_o} = \frac{|S_2|}{S_1}$$

# foundations of geometrical optics - lenses

**Thin lens formula:** ( $d$  is small compared to  $R_1$  and  $R_2$ )

In some cases (distance  $S_1 < f$ ) resulting  $S_2$  is negative, indicating that the image is formed on the opposite side of the lens from where those rays are being considered. Since the diverging light rays emanating from the lens never come into focus, and those rays are not physically present at the point where they appear to form an image, this is called a **virtual image**.

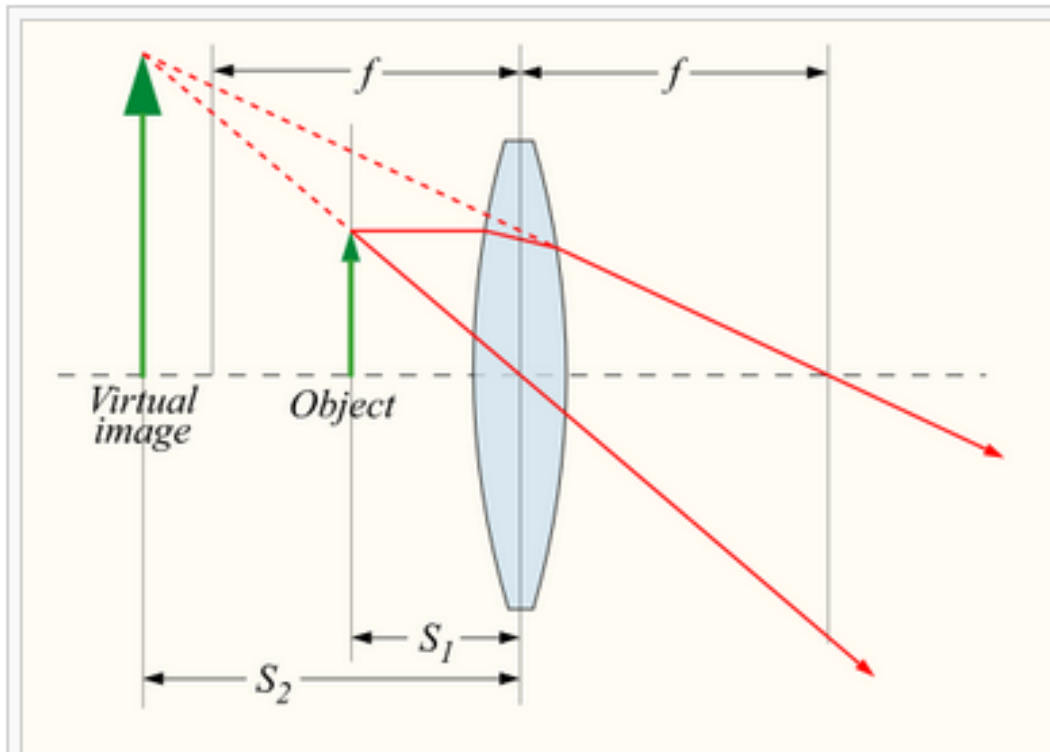

Virtual image formation using a positive lens as a magnifying glass.

In this case we often speak about so called magnifying lenses.

Beside the parameter magnification we often speak about so called optical power:

$$P = \frac{1}{f}$$

Unit is  $m^{-1}$ , often called as dioptré [D =  $m^{-1}$ ].

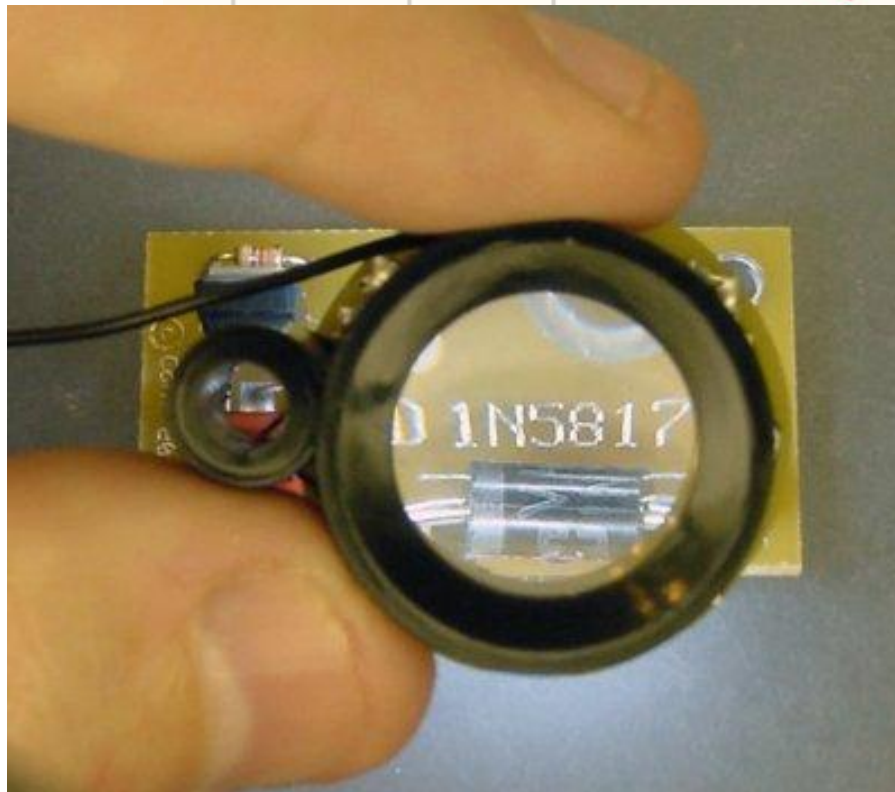
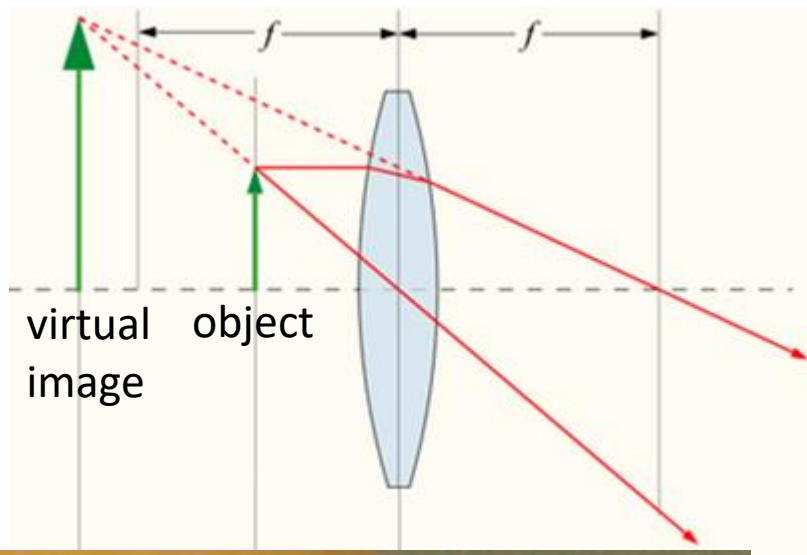

principle  
of a loupe  
(magnifier or  
microscope)

## Optical (light) microscope:

Uses visible light and a system of lenses to magnify images of small samples.

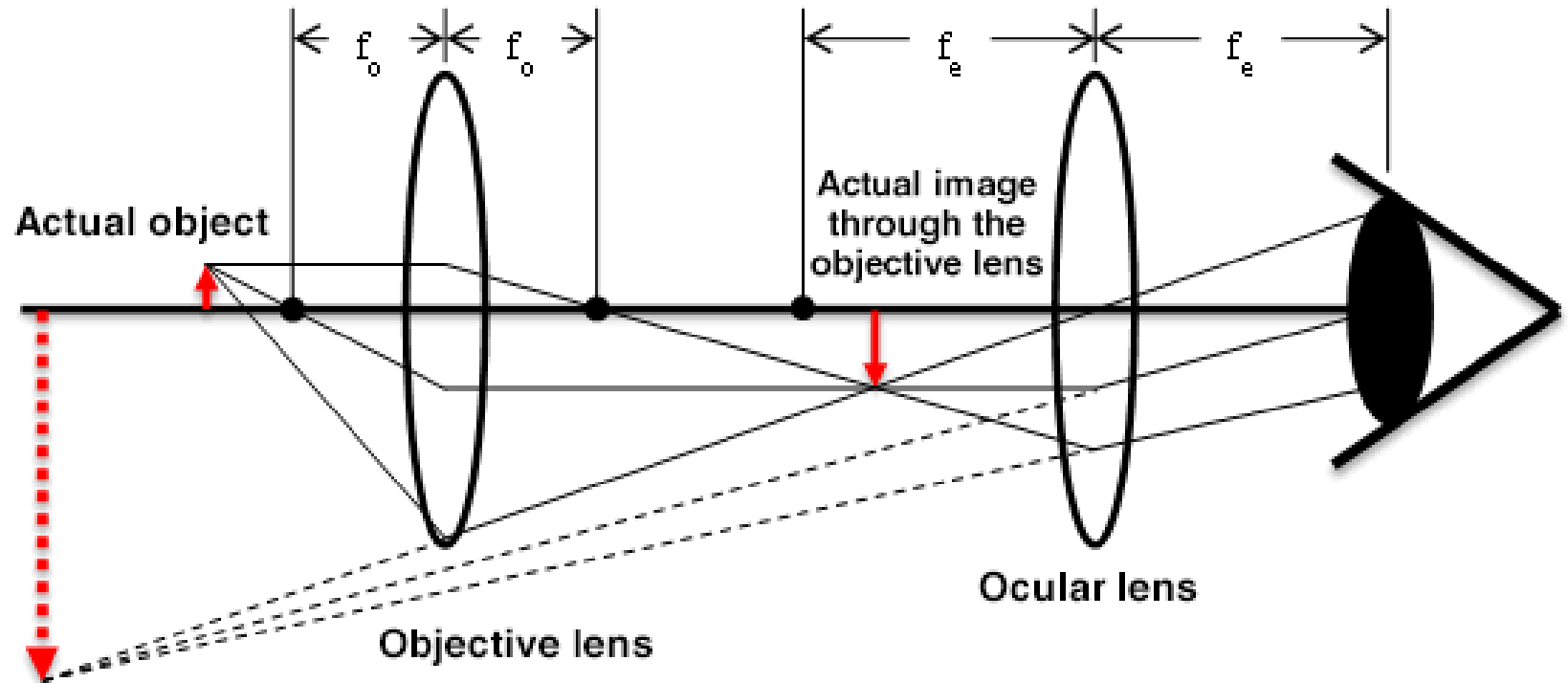
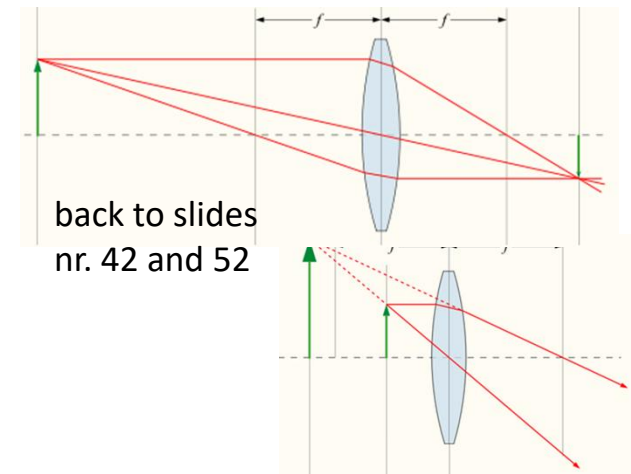
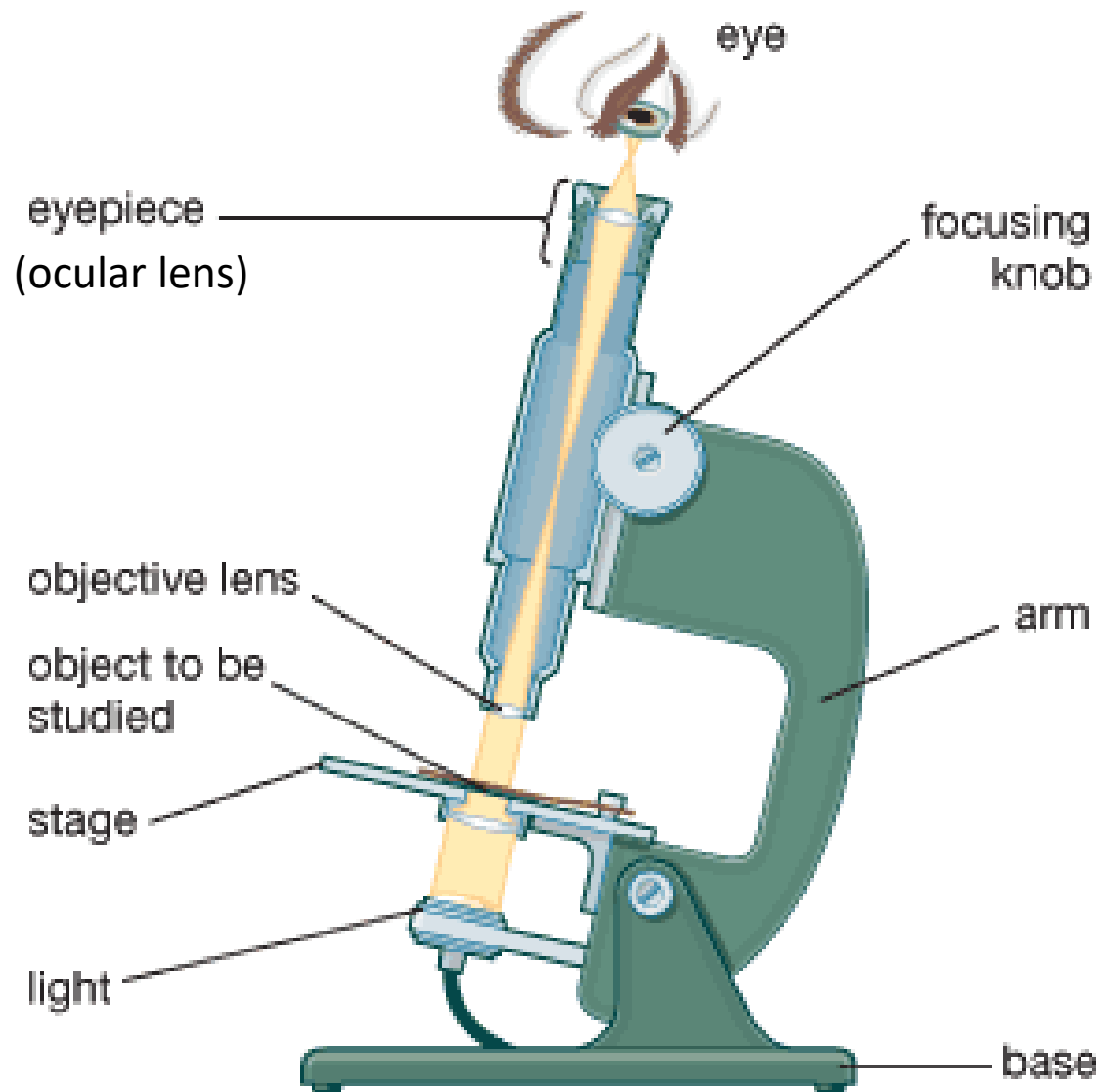

Image observed through the ocular lens  
(virtual image magnified by the ocular lens)

## Optical (light) microscope:



## Optical (light) microscope:

### Robert Hooke (1635 - 1703)

- built one of the first useful compound microscopes
- observed structure of cork
- introduced the term “cell”
- published the book *Micrographia* (1665)

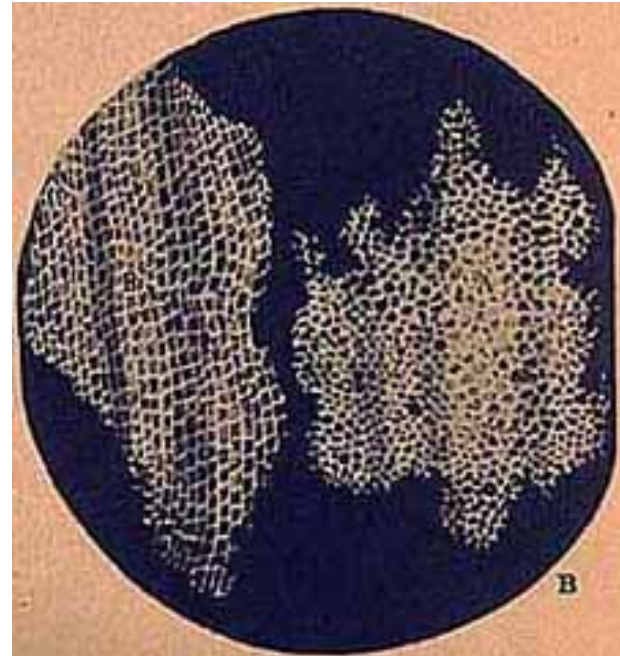
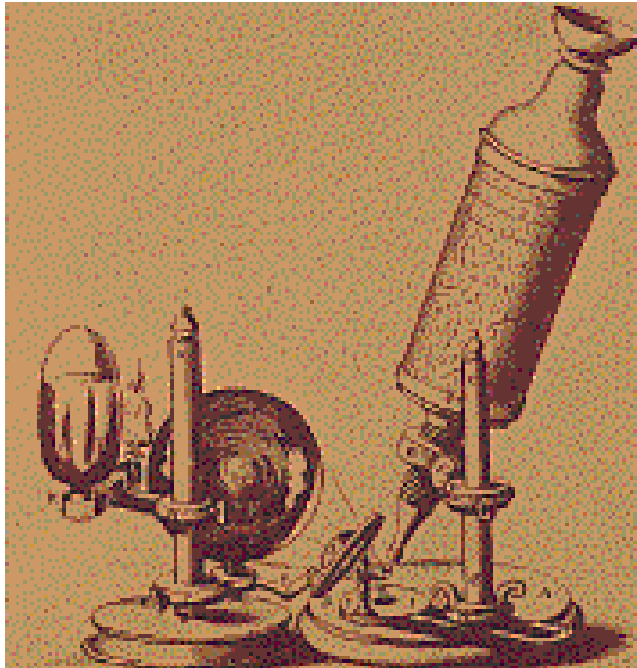

# Optical (refracting) telescope:

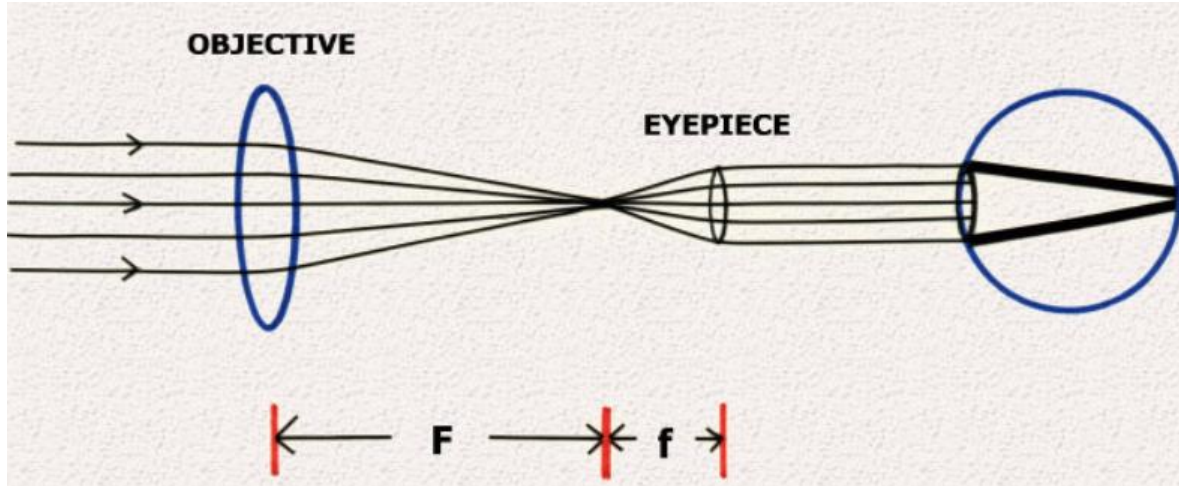

reason of parallel rays  
in the case of distant objects

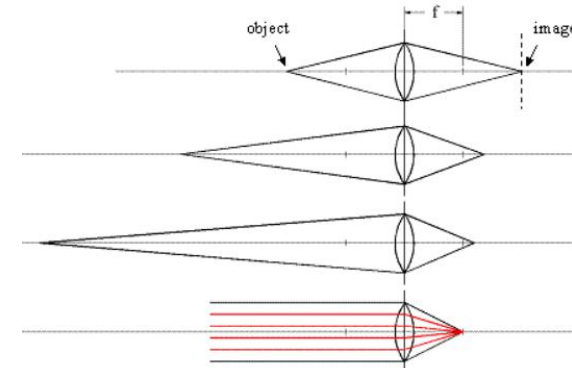

In order to look through a telescope we need two lenses, the objective , which is the principal lens of the telescope, and an eyepiece.

The image scale in the focal place is determined by the focal length of the objective - if we look through the telescope, the magnification will be determined by the ratio of the focal lengths of the objective and the eyepiece.

From the history: In 1608, Hans Lippershey, a German-born Dutch spectacle-maker, demonstrated the first refracting telescope, the forerunner of the modern optical telescope. Galileo Galilei improved on this design the following year and applied it to astronomy.

## foundations of geometrical optics - lenses

**Spherical aberration** occurs because spherical surfaces are not the ideal shape for a lens.

Spherical aberration causes **beams** parallel to, but distant from, the lens axis to be focused in a slightly different place than beams close to the axis (like there would exist **several focal points**).

This manifests itself as a **blurring of the image**.

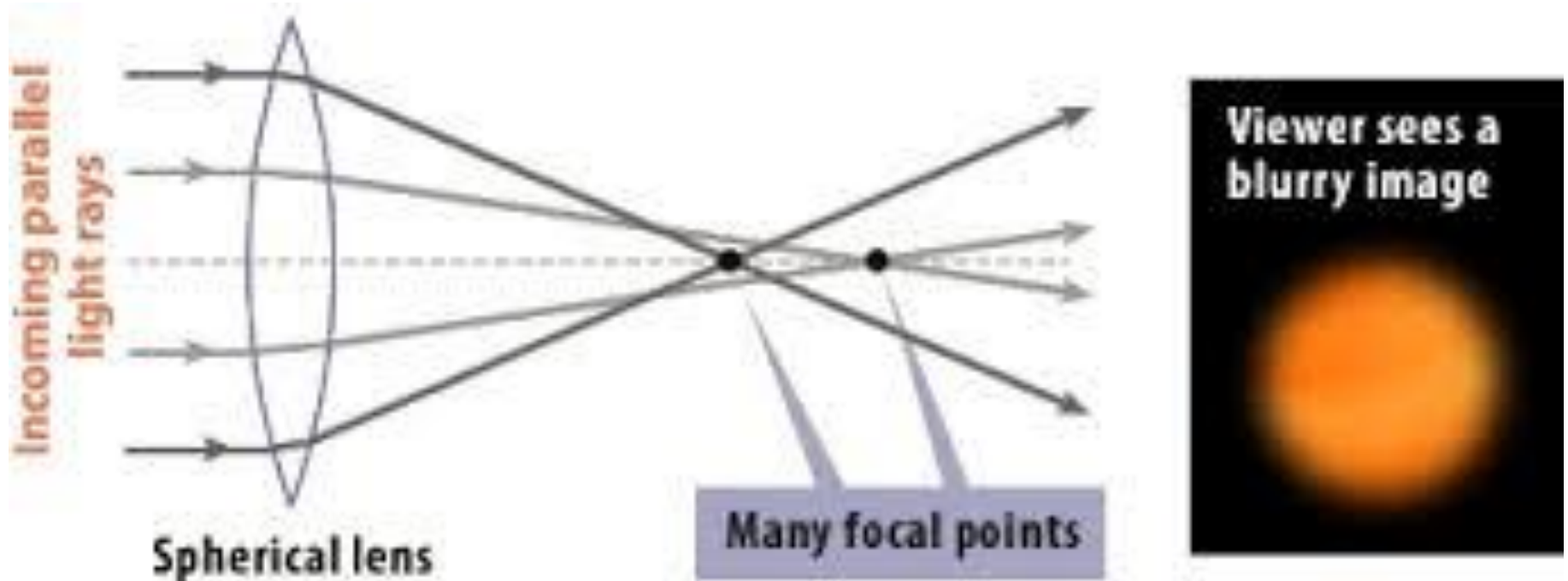

# foundations of geometrical optics – mirrors (concave and convex)

## concave mirror

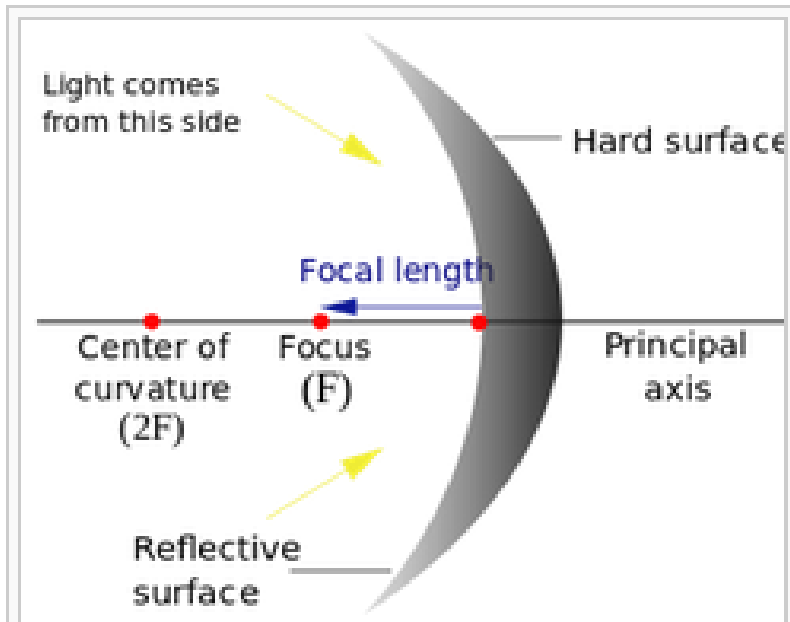

A concave mirror diagram showing the focus, focal length, centre of curvature, principal axis, etc.

converging light

## convex mirror

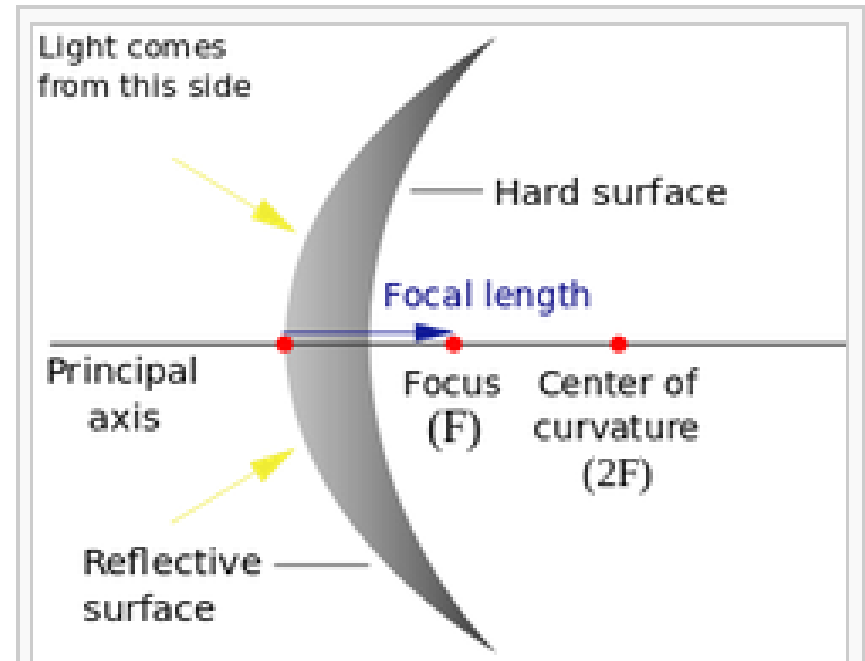

A convex mirror diagram showing the focus, focal length, centre of curvature, principal axis, etc.

diverging light

concave mirror converging light

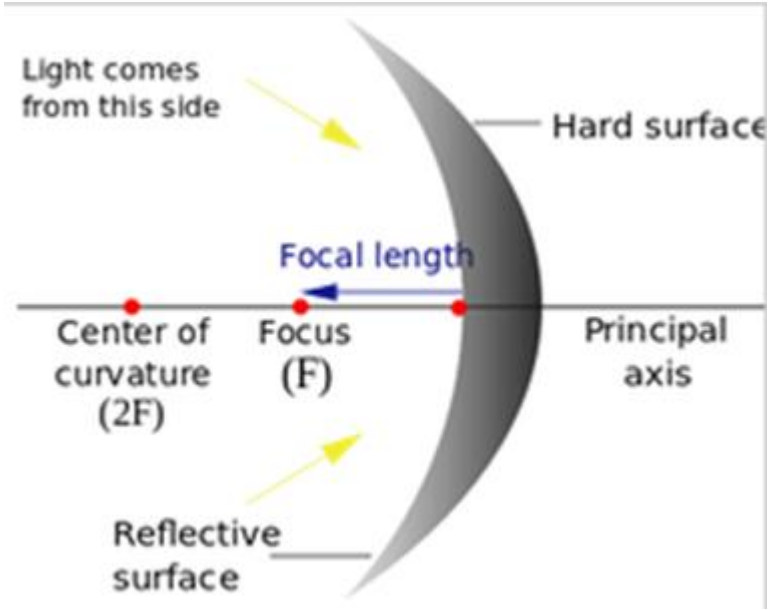

convex mirror diverging light

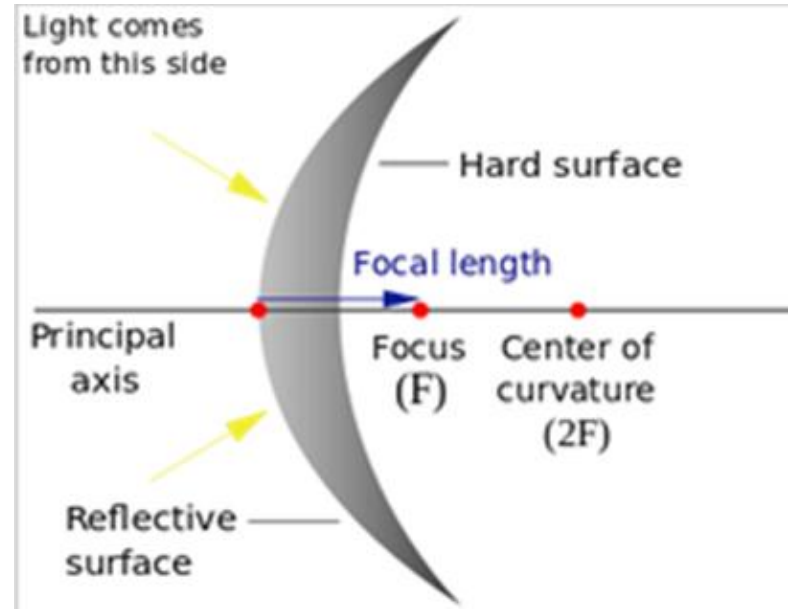

concave mirror converging light

convex mirror diverging light

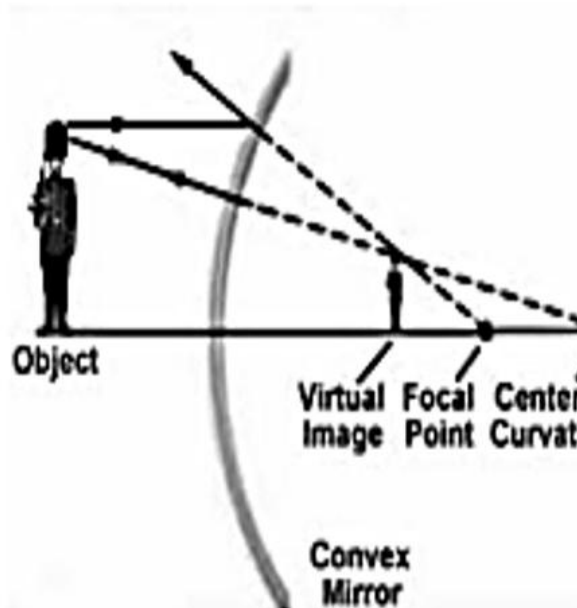
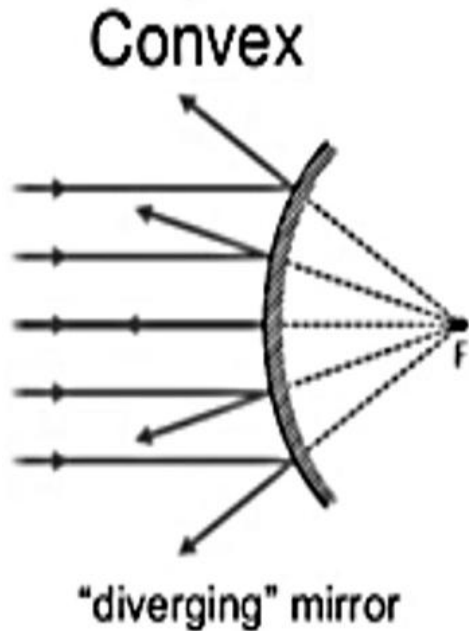
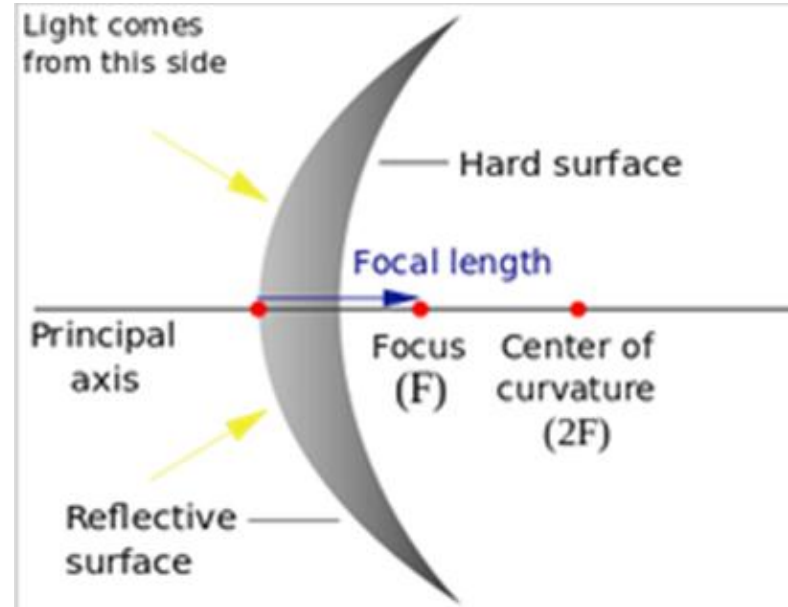

# polarised light

- light vibrates (oscillates) in all directions,
- a polarizing filter acts like a picket fence. It only lets certain direction vibrations pass through it,
- therefore, if you pass light through two of them you can completely block the light from passing through.

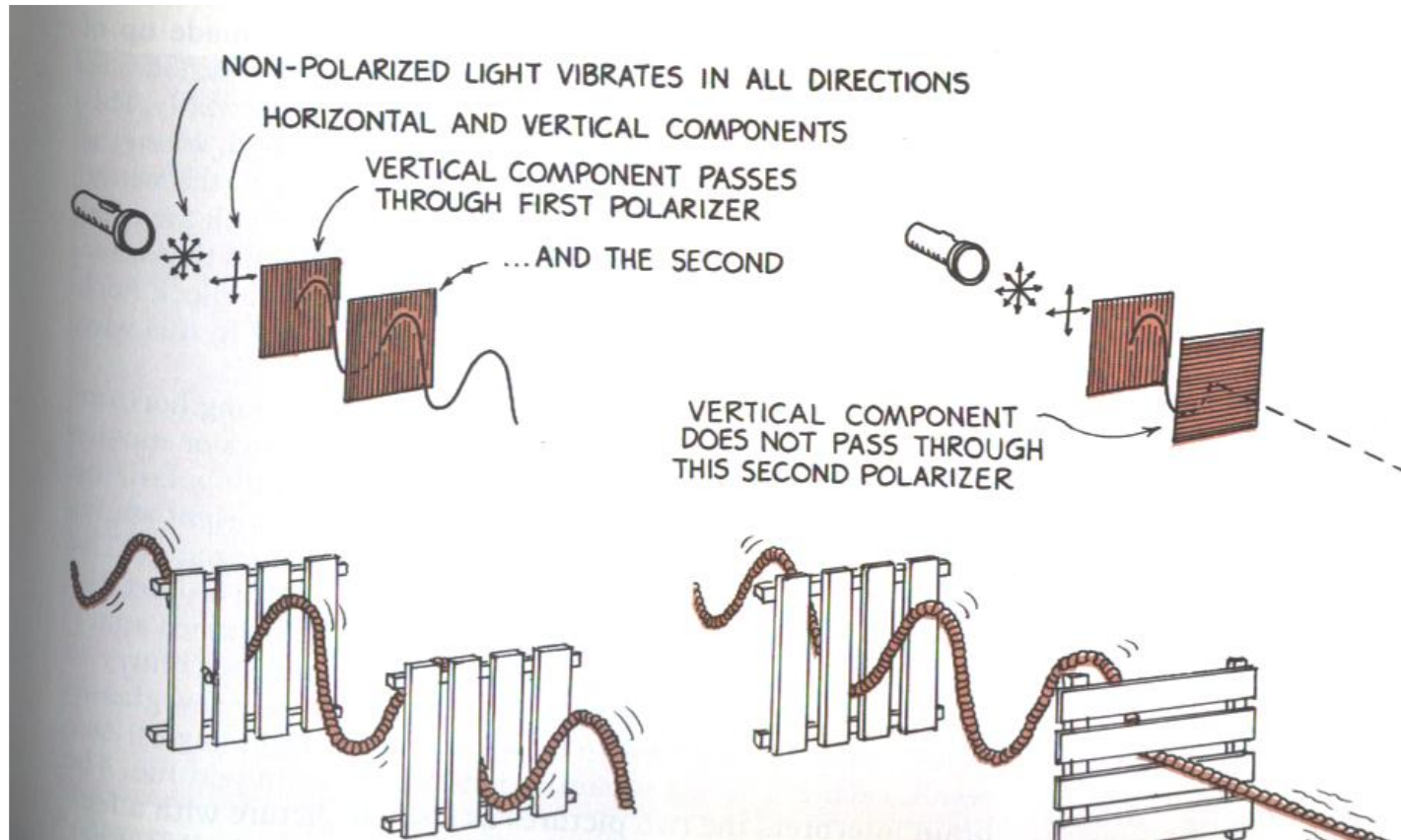

example with the rotation of polarisation filters:

<https://www.youtube.com/watch?v=p8ZxUL5MyuQ>

# polarised light

this is used in science (e.g. so called polarising microscope) and in technology (e.g. sun-glasses and 3-D movies)...

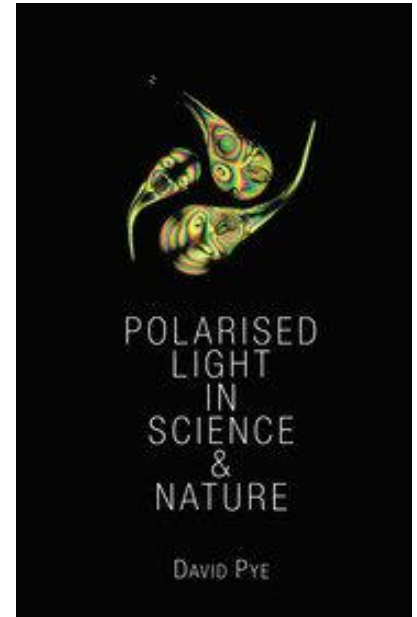
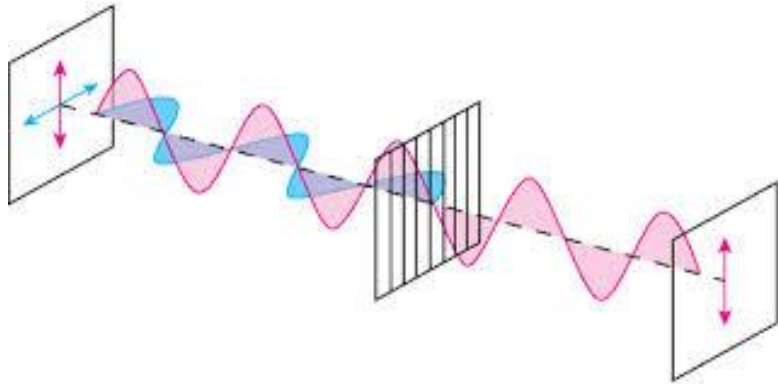

*Inclined Monocular Polarising Microscope*

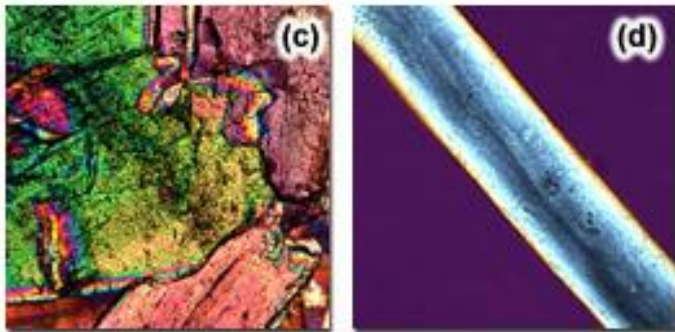

Mineral

Fiber

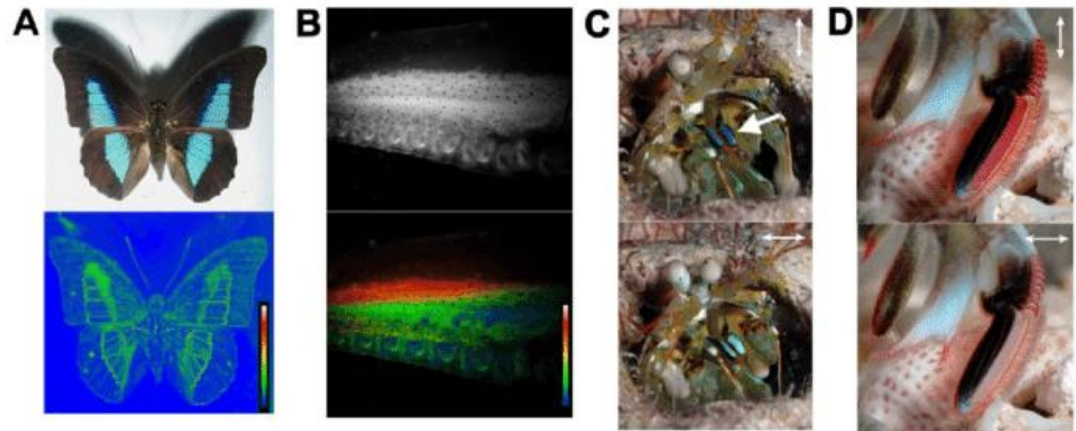

# polarised light

... product defects inspection

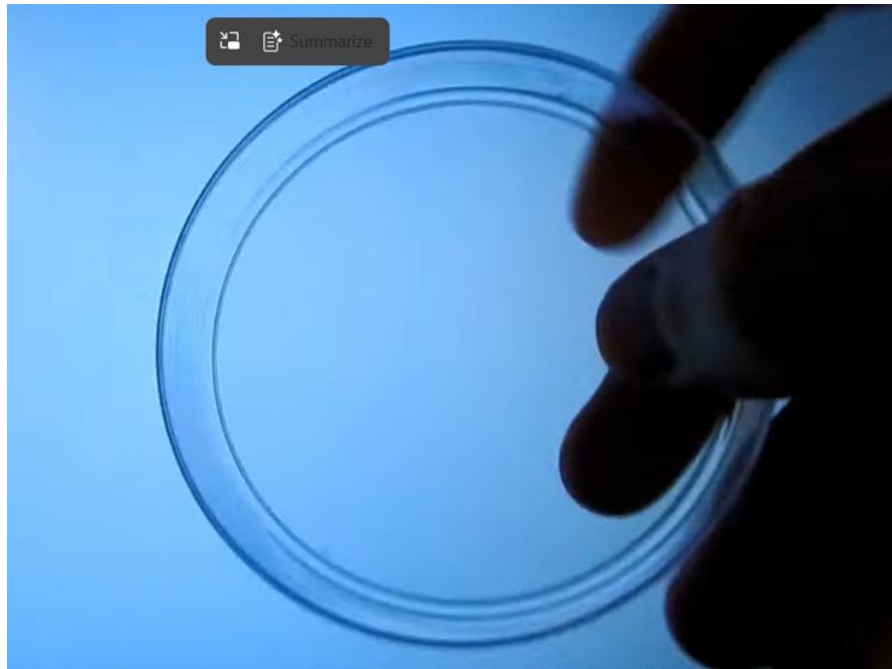

normal light

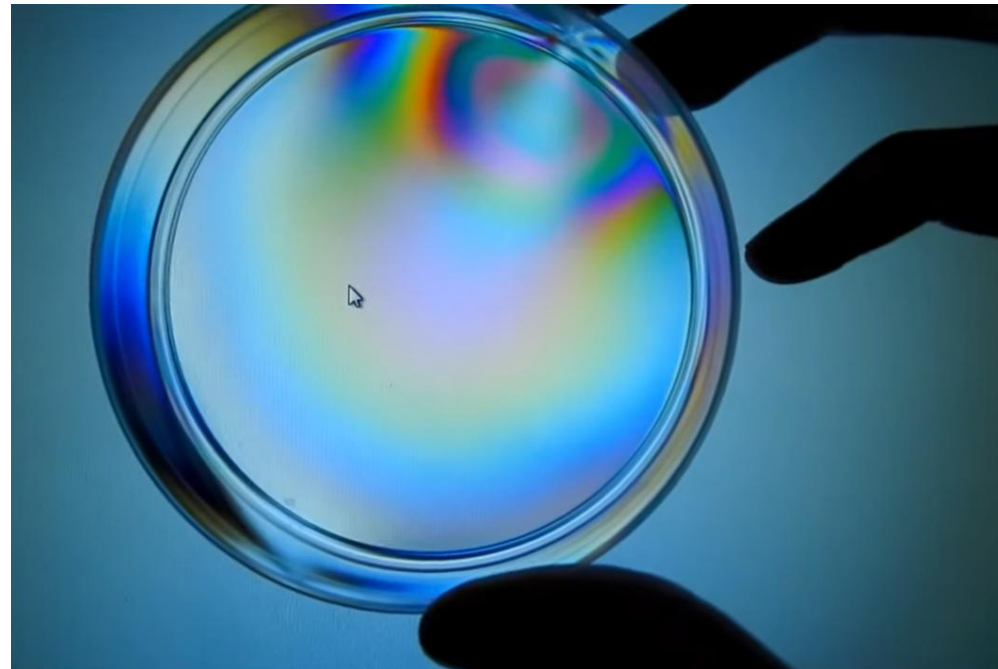

polarised light

# luminescence

**Luminescence** = emission of light by certain materials when they are relatively cool. It is in contrast to light emitted from incandescent bodies (such as fire). It is a spontaneous emission of radiation from an electronically or vibrationally excited species not in thermal equilibrium with its environment.



some minerals can also emit light, based on luminescence  
– after a reaction with special EM radiation



hydrogen peroxide  
luminescence



jellyfish luminescence

# Laser

A **laser** is a device that emits light through a process of optical amplification based on the stimulated emission of electromagnetic radiation.

The term "laser" originated as an acronym for "**Light Amplification by Stimulated Emission of Radiation".**

The first laser was built in 1960 by **T.H. Maiman** at Hughes Research Laboratories, based on theoretical work by **C.H. Townes** and **A.L. Schawlow**.

**A laser differs from other sources of light in that it emits light coherently** (coherent wave sources have a constant phase difference).

Sun light  
(polychromatic) (no coherent)

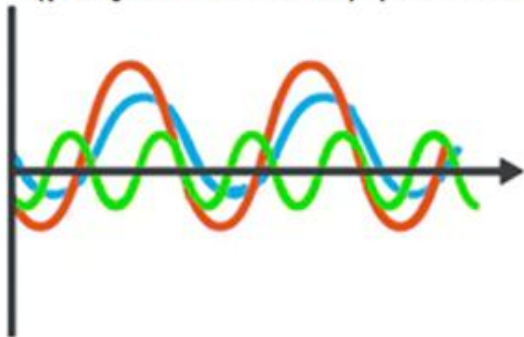

LED, monochromatic  
(no coherent)

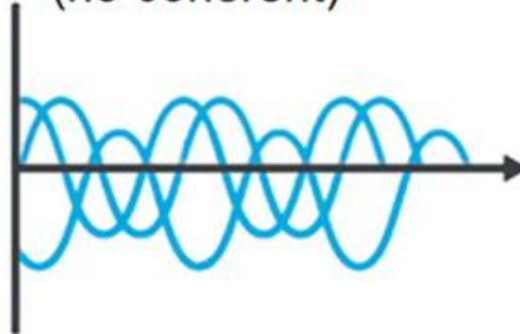

laser, monochromatic,  
coherent

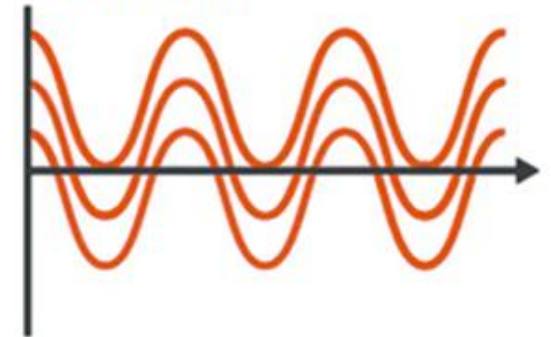

# Laser

Spatial coherence **allows a laser to be focused to a tight spot**, enabling applications such as laser cutting and lithography.

Spatial coherence also **allows a laser beam to stay narrow over great distances** (collimation), enabling applications such as laser pointers. Lasers can also have high temporal coherence, which allows them to emit light with a **very narrow spectrum**, i.e., they can emit a **single color of light**.

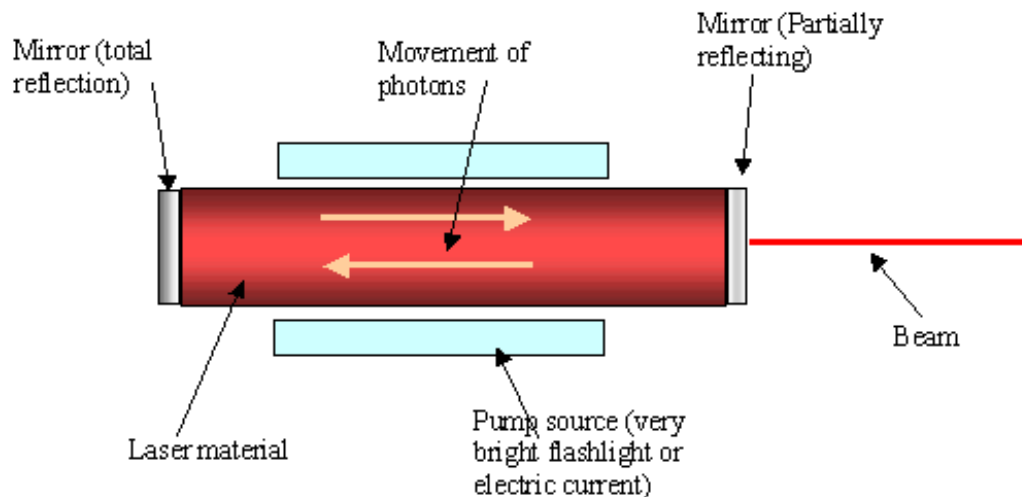

# Laser

Spatial coherence **allows a laser to be focused to a tight spot**, enabling applications such as laser cutting and lithography.

Spatial coherence also **allows a laser beam to stay narrow over great distances** (collimation), enabling applications such as laser pointers. Lasers can also have high temporal coherence, which allows them to emit light with a **very narrow spectrum**, i.e., they can emit a **single color of light**.

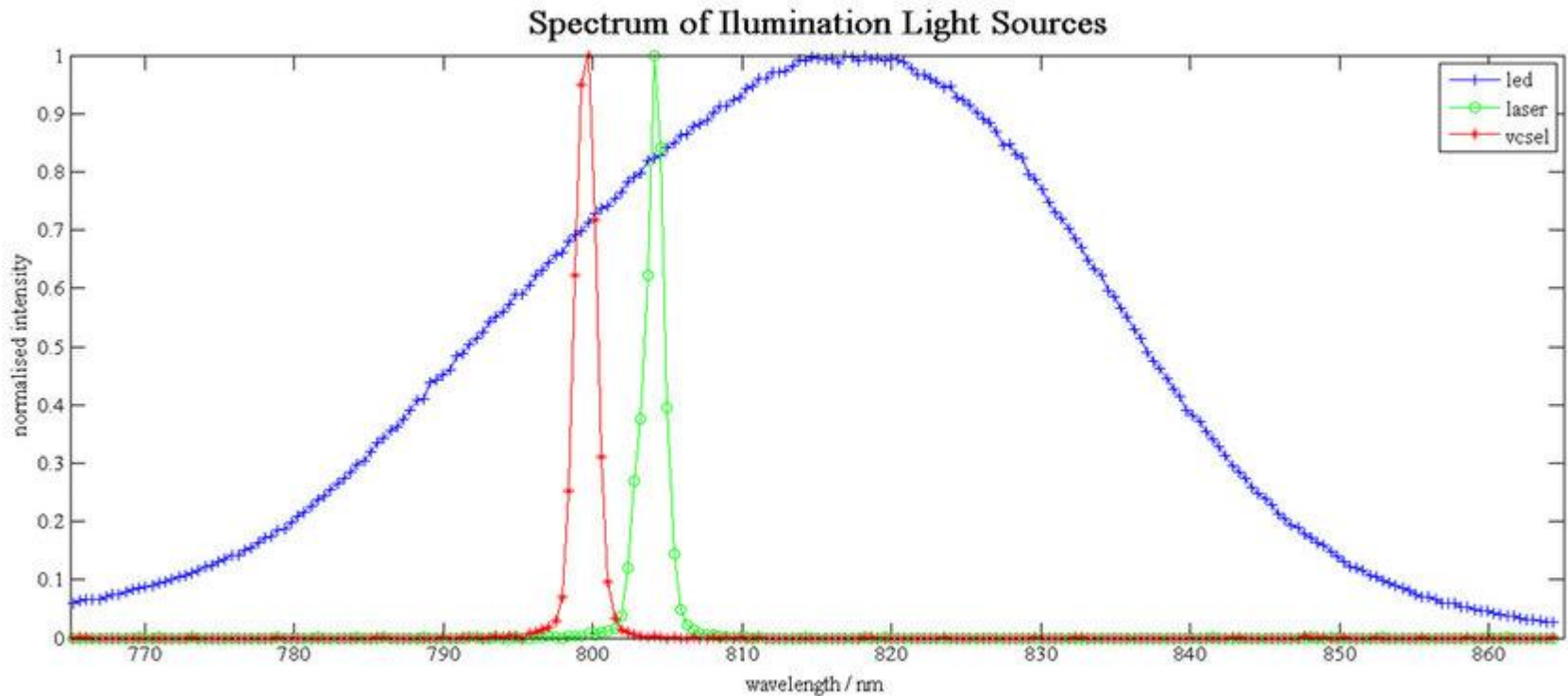

# Electron microscope:

An electron microscope is a microscope that **uses a beam of accelerated electrons as a source of illumination**. Because the wavelength of an electron can be up to 100,000 times shorter than that of visible light photons, the electron microscope has a higher resolving power than a light microscope and can reveal the structure of smaller objects.

A transmission electron microscope (TEM) can achieve better than 50 pm resolution and magnifications of up to about 10,000,000x (whereas most optical microscopes are limited by diffraction to about 200 nm resolution and useful magnifications below 2000x).

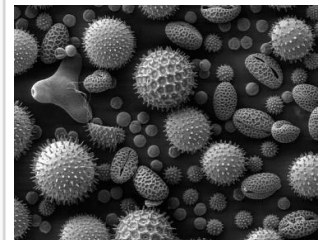
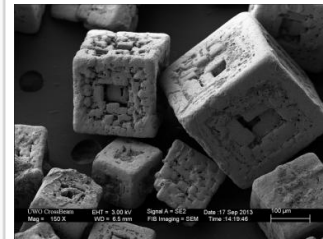
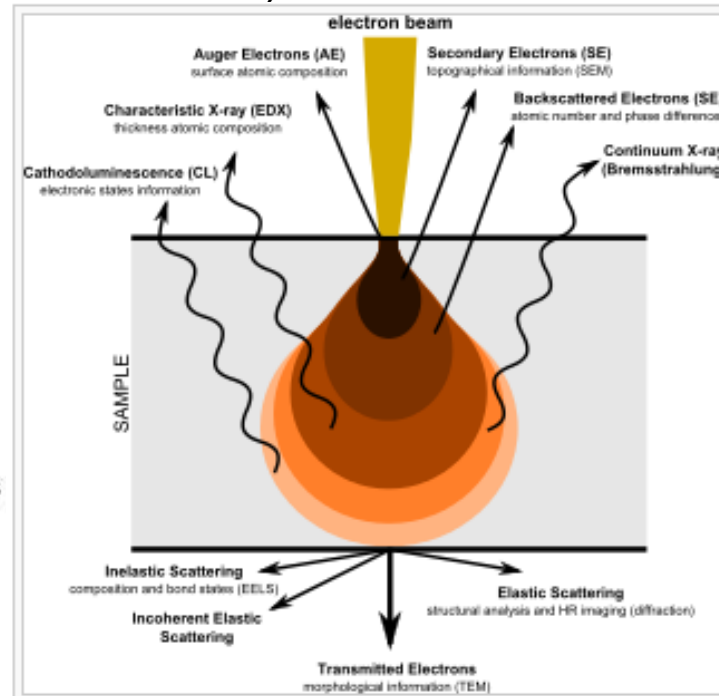
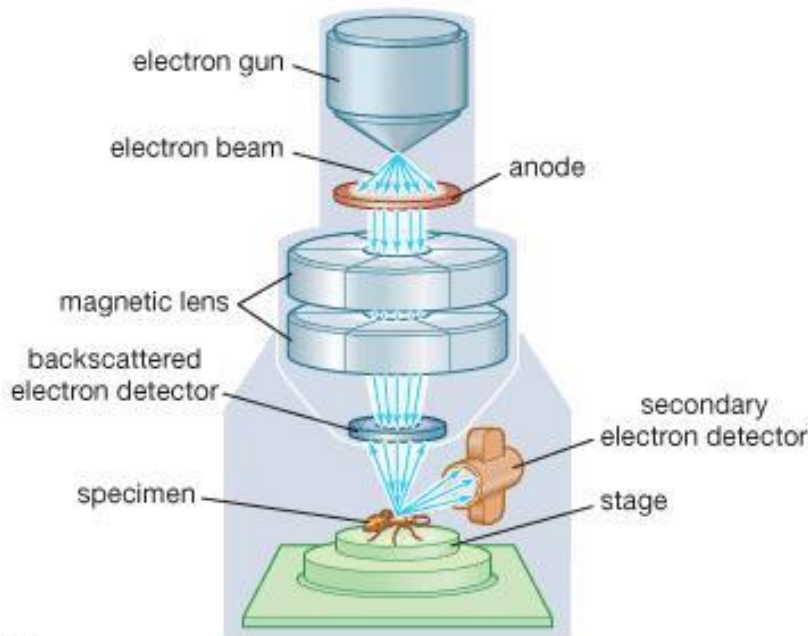

Diagram illustrating the phenomena resulting of the interaction of highly energetic electrons with matter.

# Lecture 10: optics

## Content:

- introduction to optics
- reflection VS refraction
- geometrical optics, lenses, mirrors
- microscope
- electron microscope, laser
- **black body radiation**
- **units: lumen, lux, candela**

## black body radiation – important part of EM physics

A **black body** is an idealized physical body that **absorbs all incident electromagnetic radiation**, regardless of frequency or angle of incidence. An opposite case - a **white body** (with a rough surface) **reflects all incident rays completely** and uniformly in all directions.

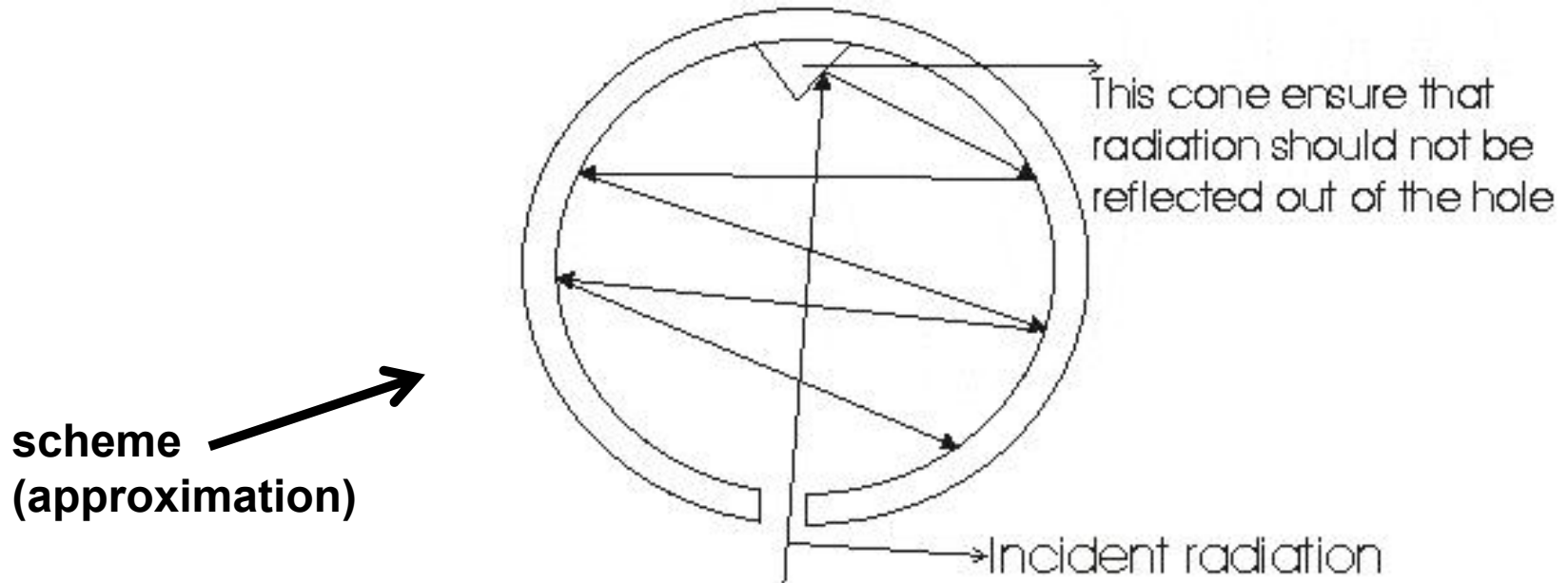

A black body absorbs all radiation incident upon it, but due to the energy conservation law it re-radiates the energy – by means of thermal radiation. This radiation has its typical character and it is not dependent upon the type of radiation which is incident upon it.

# black body radiation – important part of EM physics

Spectrum of the blackbody radiation:

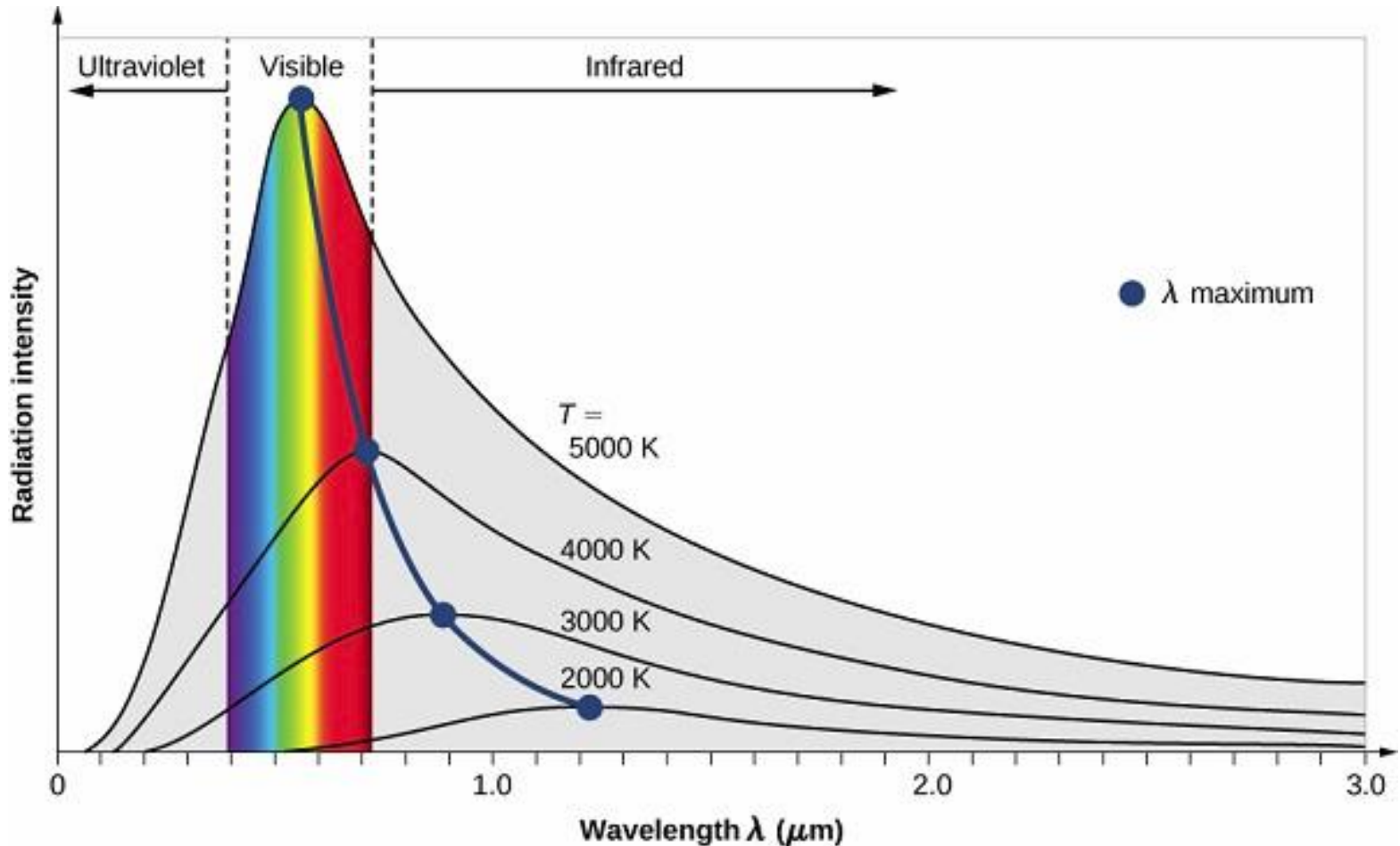

Black-body radiation is the type of electromagnetic radiation within or surrounding a **body in thermodynamic equilibrium with its environment.**

## black body radiation – important part of EM physics

Based on the **classical physics EM theory** (so called Rayleigh-Jeans law), the **energy of blackbody radiation should be shared by all wavelengths of light** (emitting more energy as the frequency increases). This yield a total sum of emitted energy, which was too high – so called „**the ultraviolet catastrophe**“. Experiments have shown different character of the spectrum of emitted radiation – some wavelengths get more energy than others. This behaviour was then **later explained by Plank's law of energy quantization**.

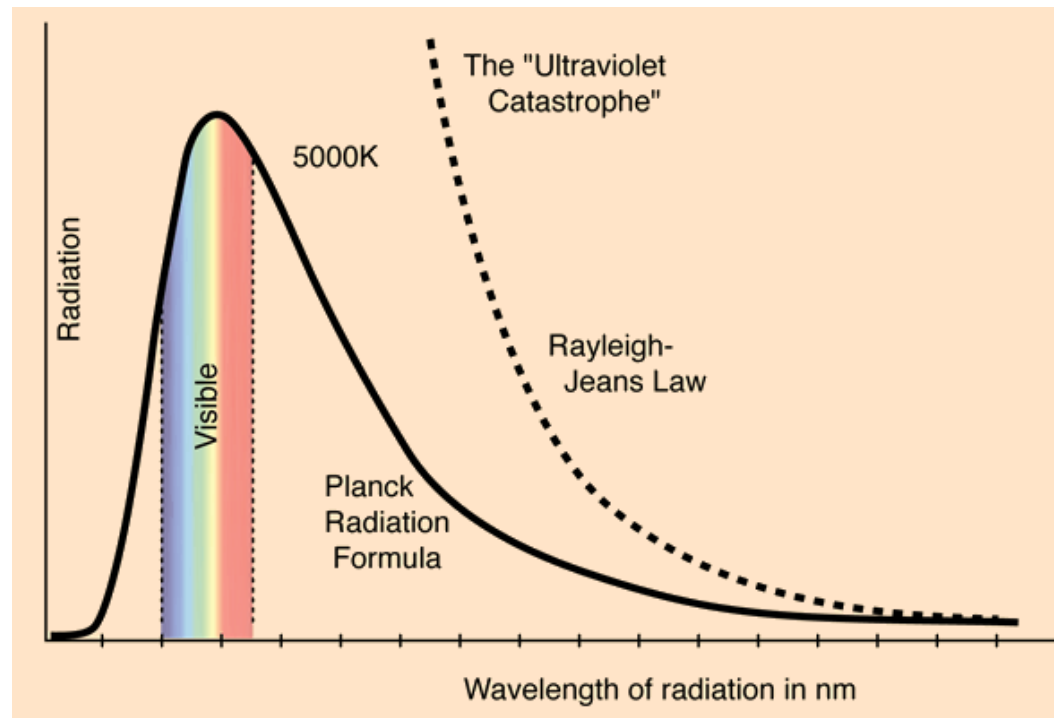

Good explanation:

<https://www.youtube.com/watch?v=7BXvc9W97iU>

## Unit of luminous intensity – candela

The **candela** (cd) is the SI basic unit of **luminous intensity** ( $J$ ); that is, luminous power per unit solid angle emitted by a point light source in a particular direction.

Comment (definitions):

Luminous intensity is a measure of the wavelength-weighted power emitted by a light source in a particular direction per unit solid angle.

Solid angle (symbol:  $\Omega$ )

is the two-dimensional angle in three-dimensional space (unit: a steradian, symbol: sr).

A full sphere has a solid angle of  $4\pi$  sr.

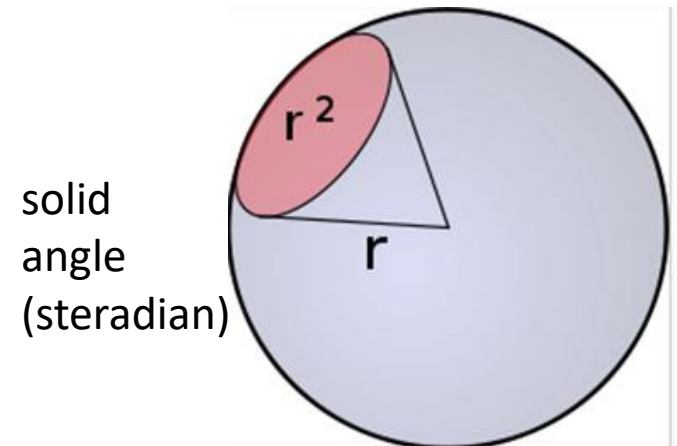
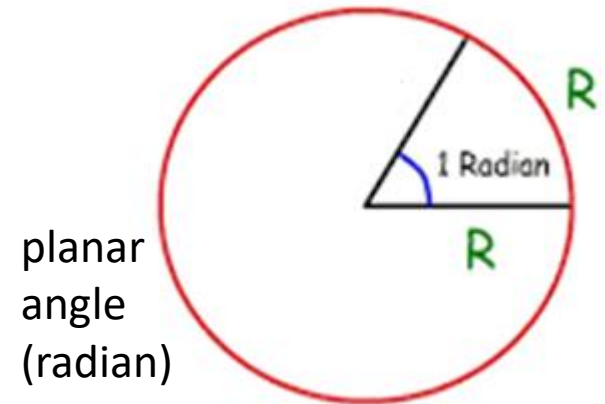

## Unit of luminous intensity – candela

The candela (symbol: cd) is the SI base unit of luminous intensity ( $J$ ); that is, luminous power per unit solid angle emitted by a point light source in a particular direction.

### Original definition (1946):

One candela is defined as: The brightness of the full radiator at the temperature of solidification of platinum is 60 candelas per square centimetre.

### Older definition (1979):

The luminous intensity, in a given direction, of a source that emits monochromatic radiation of frequency  $540 \cdot 10^{12}$  Hz and has a radiant intensity of  $1/683$  watt per steradian.

### Actual definition:

The candela is defined by taking the fixed numerical value of the Luminous efficacy of monochromatic radiation of frequency  $540 \cdot 10^{12}$  Hz,  $K_{\text{cd}}$ , to be 683 when expressed in the unit  $\text{lmW}^{-1}$ , which is equal to  $\text{cdsrW}^{-1}$  or  $\text{cdsrkg}^{-1}\text{m}^{-2}\text{s}^3$ , where the kilogram, metre and second are defined in terms of  $h$ ,  $c$  and  $V_{\text{Cs}}$ .

## Unit of luminous intensity – candela

Connection to the units **lumen** and **lux**.

The lumen (symbol: lm) is the SI derived unit of **luminous flux**, a measure of the total quantity of visible light emitted by a source.

The lumen is defined in relation to the candela as:  $1 \text{ lm} = 1 \text{ cd} \cdot \text{sr}$ .

**Lumens are related to lux in that 1 lux is 1 lumen per square meter** (lux, symbol: lx is the SI derived unit for illuminance).

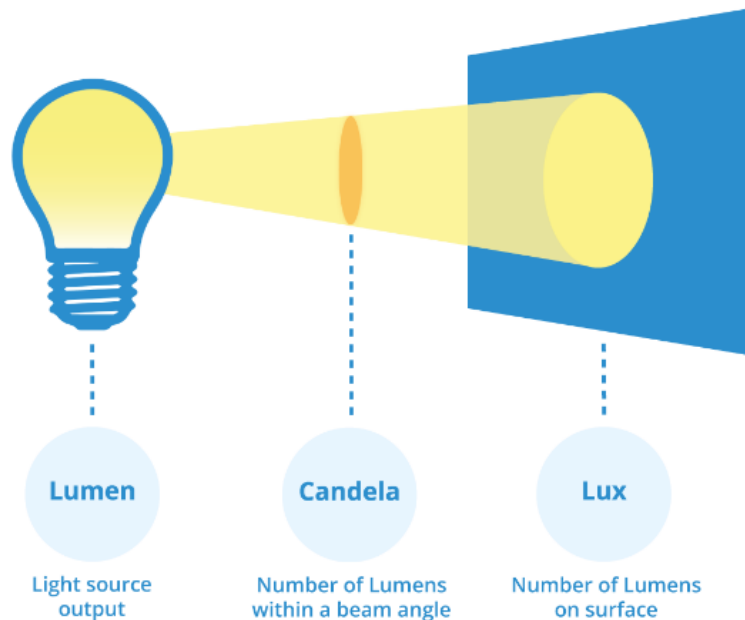

A full sphere has a solid angle of  $4\pi$  steradians, so a light source that uniformly radiates one candela in all directions has a total luminous flux of  $1 \text{ cd} \cdot 4\pi \text{ sr} = 4\pi \text{ cd} \cdot \text{sr} \approx 12.57$  lumens.

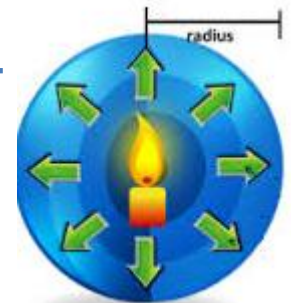

## Topic 8: light, optics

### Summary:

- visible light: wavelengths from about 400 to 700 nm
- law of reflection and law refraction (Snell's law)

$$\frac{\sin \theta_1}{\sin \theta_2} = \frac{v_1}{v_2} = \frac{n_2}{n_1}$$

- biconvex lens, thin lens formula  $\frac{1}{S_1} + \frac{1}{S_2} = \frac{1}{f}$
- optical microscope, telescope
- electron microscope, LED, laser
- black body radiation – first mention of Plank's law of energy quantization
- definitions of units: lumen, lux, candela